

WESTPRO high frequency screen



applications

Westpro's high frequency screen unit is designed for a vast range of applications.

- Slurry processing for mining
- Solids control
- Oil & gas fluid recovery
- Solid – liquid separation
- Fines removal

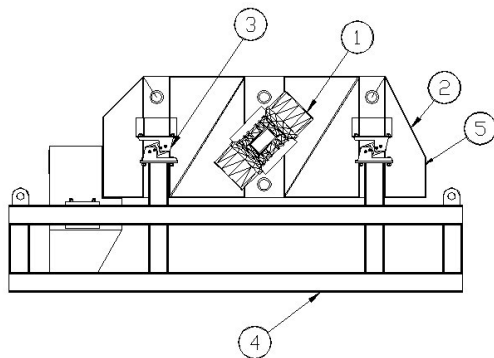

advantages

- Variable, high G force
- Simple and reliable design
- Low maintenance
- Quick screen changeovers

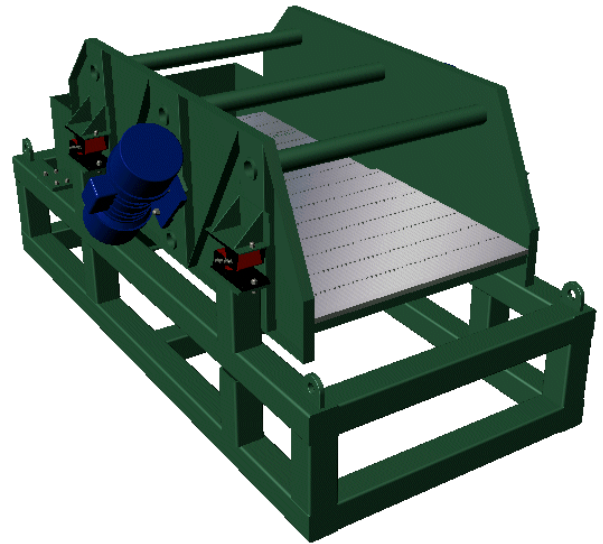

components

- 1. Vibration Motors**
 - Adjustable speed
 - Low noise
- 2. Feed Box**
 - Simple, durable design
 - High impact strength
 - Heavy duty construction
- 3. Vibration Dampeners**
 - Polymer vibratory material
 - Effective vibration isolation
- 4. Understructure**
 - Heavy duty design
 - Easily installed
- 5. High Frequency Screens**
 - Wide range of mesh sizes
 - Quickly interchangeable

Westpro Machinery Inc.
P.O. Box 726
Vernon, BC
Canada V1T 6N6
Tel: (250) 549-6710
Fax: (250) 549-6735
Toll Free: 1-877-WESTPRO (937-8776)
Email: sales@westpromachinery.com