

WESTPRO cone crushers

applications

SECONDARY CRUSHING

- Mining
- Aggregate
- Demolition
- Industrial
- Construction
- Environmental

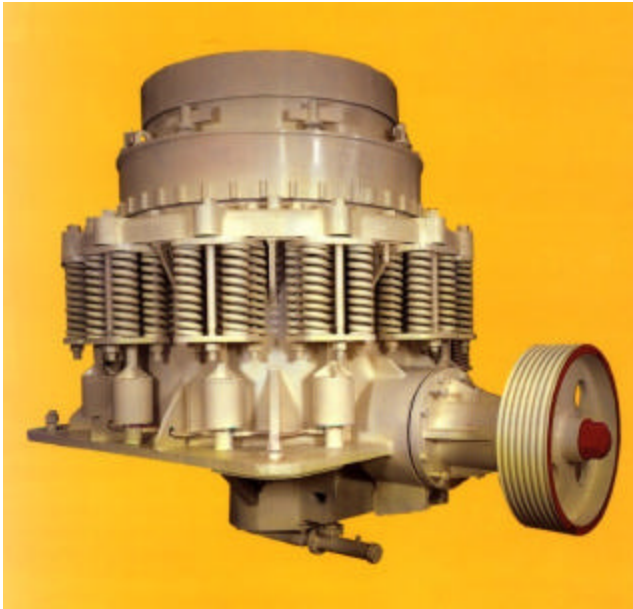

DIMENSION

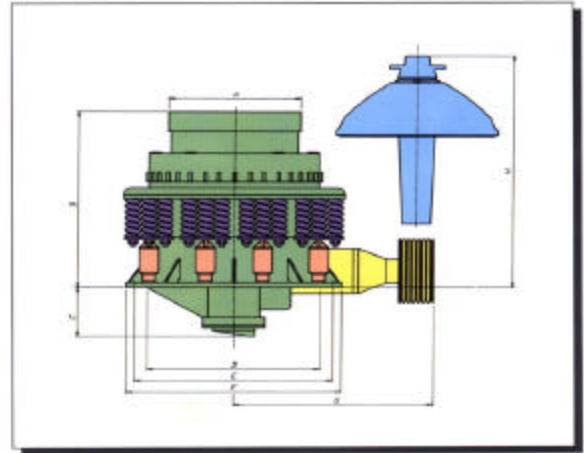

MODEL	A	B	C	D	E	F	G	H
900	1060	1760	475	1300	1500	1860	1580	2700
1200	1361	1930	580	1635	1800	2070	2040	3200
1800	1850	2450	785	2060	2300	2650	2400	3800

REMARK: The dimension table above is made from the standard layout.
At the actual installation we will submit the detailed drawing separately.

advantages

- Hydraulic Clearing
- Hydraulic Adjustment
- Heavy Duty Design
- High Productivity
- Long Life
- Standard Replacement Parts
- Cost Effective

components

CONSTRUCTION

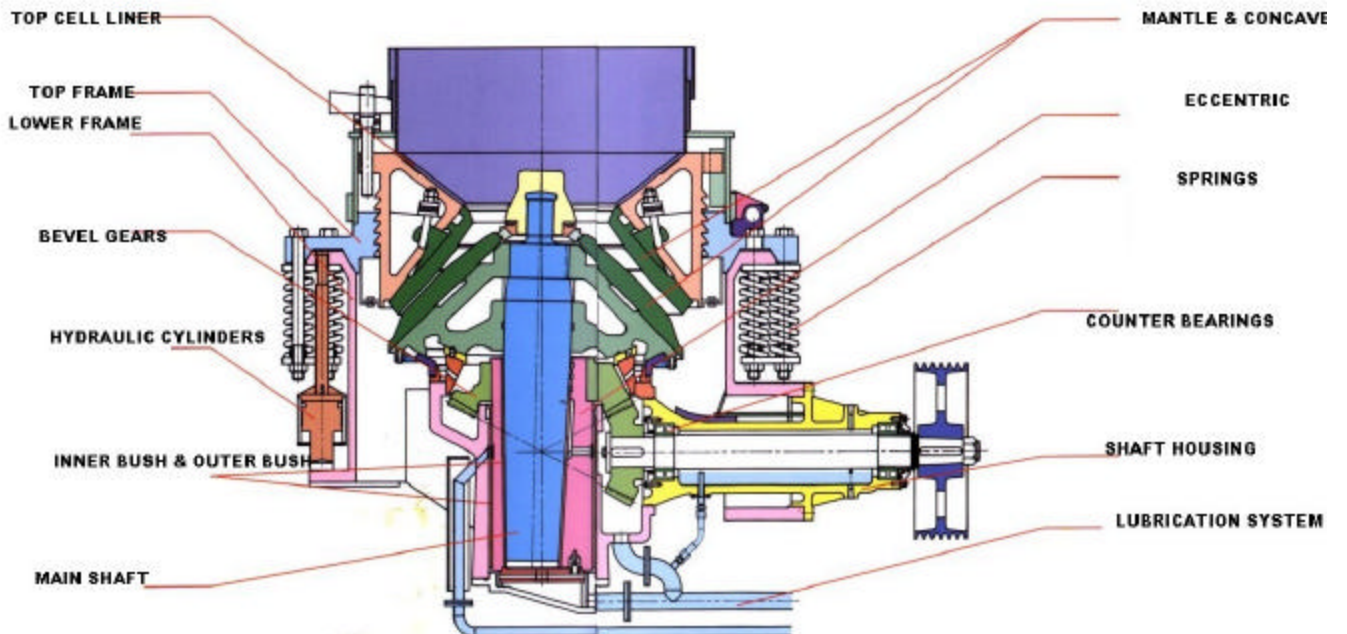

WESTPRO cone crushers

1. Spring Relief Device

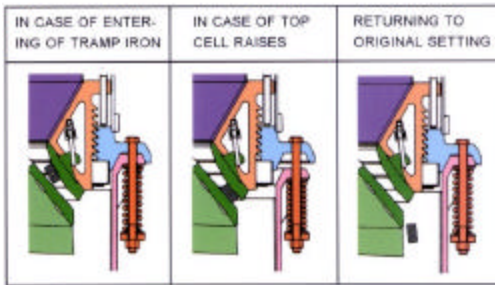

2. Hydraulic Clearing Device

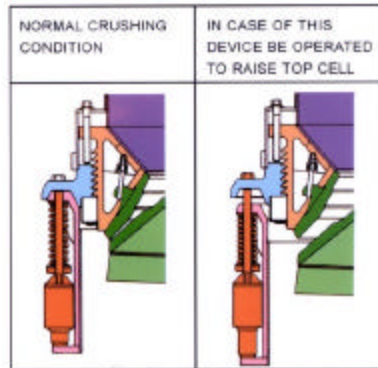

3. Hydraulic Adjusting Device

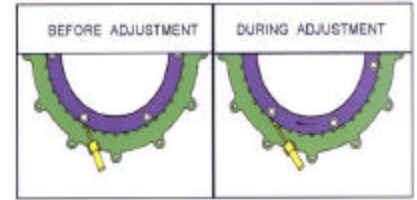

THREE TYPES OF CRUSHING CHAMBER

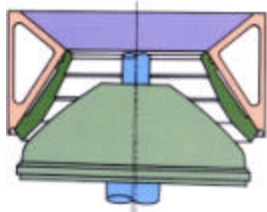

1.CC MODEL
For relatively coarse crushing.

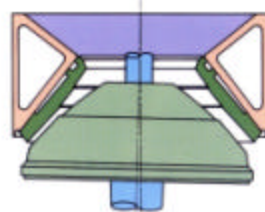

2.CF MODEL
For medium and fine crushing.

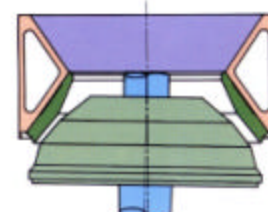

3.CSH MODEL
Short head type for fine crushing.

MODEL	Closed Side Setting (m / m)	Feed Size (m / m)	Product Sizes (m / m)	Hourly Capacity (T / H)	Power (HP)	Pulley R.P.M.	Weight (kg)
CSH900	14	18 ~ 50	0 ~ 34	61 ~ 90	75 ~ 100	630	10,500
	18	20 ~ 60	0 ~ 39	63 ~ 95			
CF900	20	30 ~ 80	0 ~ 44	69 ~ 103	75 ~ 100	630	10,500
	23	37 ~ 92	0 ~ 49	79 ~ 118			
CC900	28	40 ~ 110	0 ~ 60	96 ~ 144	75 ~ 100	630	10,500
	40	50 ~ 150	0 ~ 70	128 ~ 192			
NCSH1200	65	70 ~ 170	0 ~ 100	179 ~ 269	125 ~ 150	560	19,940
	14	18 ~ 50	0 ~ 32	92 ~ 138			
NCF1200	18	20 ~ 70	0 ~ 37	97 ~ 146	125 ~ 150	560	19,940
	20	23 ~ 80	0 ~ 43	102 ~ 153			
NCC1200	23	25 ~ 92	0 ~ 48	118 ~ 177	125 ~ 150	560	19,940
	28	30 ~ 112	0 ~ 59	144 ~ 216			
NCC1600	45	50 ~ 210	0 ~ 69	230 ~ 346	200 ~ 250	510	42,000
	80	90 ~ 250	0 ~ 111	307 ~ 461			
NCC1600	60	70 ~ 260	0 ~ 89	384 ~ 576	200 ~ 250	510	42,000
	80	90 ~ 280	0 ~ 119	486 ~ 730			

Westpro Machinery Inc.
P.O. Box 726
Vernon, BC
Canada V1T 6N6
Tel: (250) 549-6710
Fax: (250) 549-6735
Toll Free: 1-877-WESTPRO (937-8776)
Email: sales@westpromachinery.com