

WESTPRO

YOUR PROCESS TECHNOLOGY PARTNER

MINING | AGGREGATE | WASTEWATER



FOCUSED ON QUALITY.
COMMITTED ON EXCELLENCE.

www.westpromachinery.com

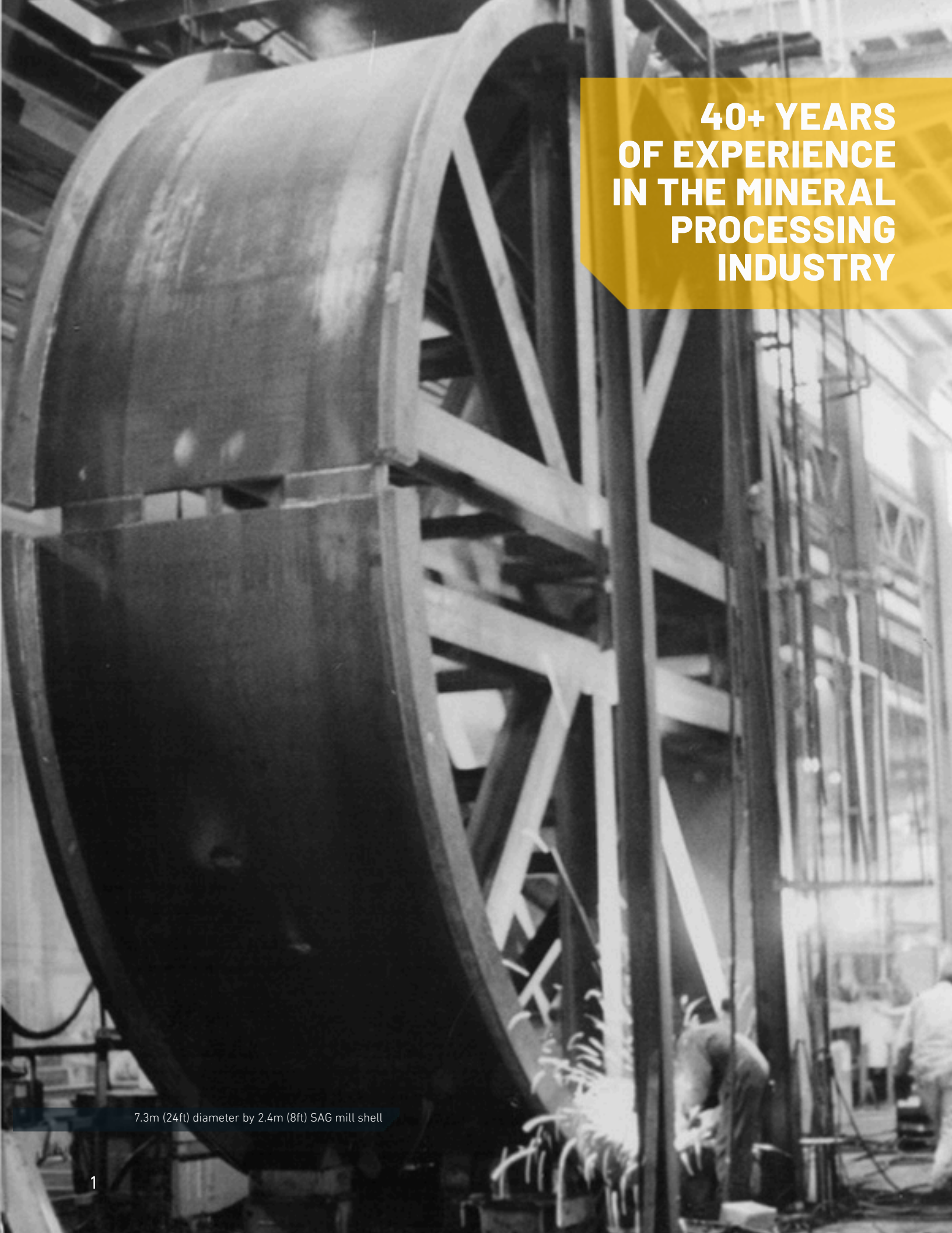
A black and white photograph of a massive industrial SAG mill shell under construction. The shell is a large, curved, cylindrical structure supported by a complex steel framework. In the background, a multi-story industrial building with a grid of windows is visible. A worker is seen in the lower right foreground, working on the structure. A yellow banner is overlaid on the top right corner.

**40+ YEARS
OF EXPERIENCE
IN THE MINERAL
PROCESSING
INDUSTRY**

7.3m (24ft) diameter by 2.4m (8ft) SAG mill shell

WESTPRO MACHINERY INC.

Your Process Technology Partner since 1985

Westpro Machinery Inc. is an innovative Canadian mineral processing technology company with over 40 years of experience in the mining, wastewater and aggregate industries. As a result of an unwavering focus on quality and customer satisfaction, Westpro's equipment is renowned world-wide for robust construction, reliability and high performance.

From mining mega-projects to pilot plant operations, Westpro has the capabilities to design and manufacture process equipment for any project scale. Additionally, the company's comprehensive range of mineral processing equipment allows it to integrate different product lines into the design of modular process plants.

Utilizing the skills of a talented and experienced team of multi-disciplinary engineers, all Westpro equipment is tailored to deliver optimum performance in each application. Additional services such as installation supervision, commissioning, process & equipment auditing and spare-parts ensure that customers are delivered a complete process technology solution.

Westpro's process equipment and systems are proven in mining operation, with installations in over 20 countries around the globe including Canada, Chile, Guatemala, Guyana, Indonesia, Mali, Mexico, Nigeria, Peru, Philippines, Russia, Saudi Arabia, Spain, Suriname, Turkey and the United States of America. With global procurement and fabrication partnerships, Westpro is ideally positioned to deliver high quality & competitive solutions to projects anywhere in the world.

Westpro's commitment to excellence has established it as an industry leader with the latest technologies, best prices, quickest deliveries and unmatched service. **Contact Westpro, your process technology partner today. Contáctenos, para nosotros será un placer servirle.**



Westpro's 2.4m (8ft) diameter chain drive agglomerator at a copper heap leach operation in Peru

THE WESTPRO ADVANTAGE

EXPERTISE

At Westpro, we know mineral processing. Our industry-leading expertise has been developed through over 40 years of experience in the design and manufacture of mineral processing technology. Our talented team of engineers combine their knowledge and skills to develop optimal solutions for the processing of a range of commodities in projects around the world.

QUALITY

The focus on quality is the cornerstone of Westpro's philosophy and is evident in the performance of our machines. Heavy duty designs ensure that Westpro's equipment delivers high performance and low maintenance operation in the toughest environments.

CUSTOM SOLUTIONS

The flexibility to tailor solutions to the specific requirements of each project is a key differentiator for Westpro. Our engineering team works closely with each customer to custom-design & manufacture equipment or process plants to meet project specific goals.

LIFE CYCLE SUPPORT

Customer satisfaction is of prime importance at Westpro. We are proud to offer the services of a multi-lingual support team to provide our customers with comprehensive support including prompt spare parts delivery, on-site assistance, technical expertise and equipment service.

INNOVATION

Committed to continuous improvement and R&D, Westpro has a proven track record of developing innovative technologies to help boost our customers' ROI. With a focus on improved operational performance, energy efficiency and reliability, you can trust Westpro's machines to give you an edge in the market

TABLE OF CONTENTS

Engineering Design Capabilities	5
Modular Process Systems	7
• Crushing Plants	9
• Grinding Plants	10
• Flotation Plants	11
• Dewatering Plants	12
• Heap Leach Ore Preparation	13
• Tailings Management Systems	14
• Fines Removal Systems	15
• Pilot and Demonstration Plants	16
Process Equipment	
• Water and Wastewater Treatment	17
• Aggregates Processing	18
• Hopper Feeders	19
• Jaw Crushers	20
• Cone Crushers	21
• Apron Feeders	22
• Agitators	22
• Agglomerators	23
• Grinding Mills	24
• Grinding Mill Accessories	25
• Attrition Scrubbers	26
• Drum Scrubbers	27
• Rotary Trommels	27
• Conventional Flotation Machines	28
• Flotation Tank Cells	29
• Thickeners	30
• Clarifiers	31
• Disc Filters	32
• Filter Presses	32
• Rotary Dryers	33
• Reagent Preparation & Dosing Systems	34
• Flocculant Preparation & Dosing Systems	35
• Lime Slaking Systems	36
• Portable Process Equipment	37
• Portable Crushers	38
• Pilot and Laboratory Equipment	39
Customer Service and Support	
• Westpro Production Facility	41
• Service and Support	42
• Grinding Mill Reconditioning	43
• Flotation Retrofits	44
• Thickener Retrofits	45

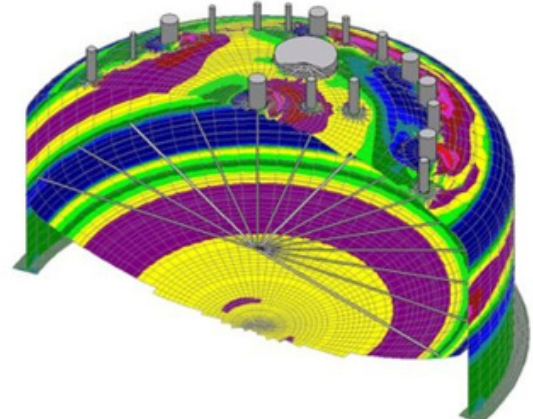
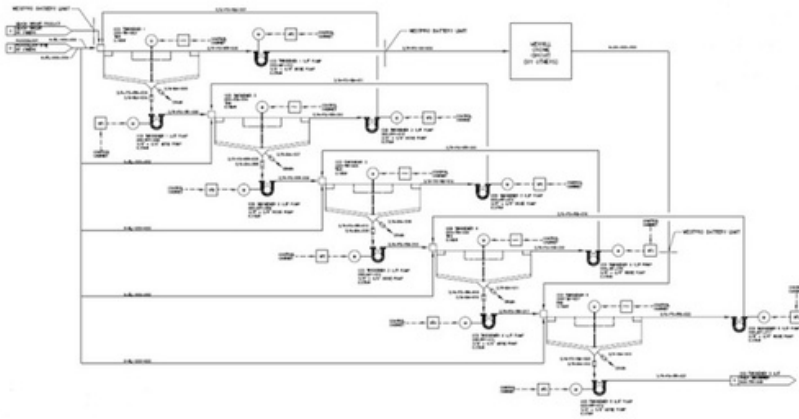

ENGINEERING DESIGN CAPABILITIES

Westpro's success has been built on a strong foundation of quality, achieved through innovative and robust engineering design. Utilizing a multidisciplinary team of process, mechanical, structural, electrical and instrumentation engineers, Westpro can offer its customers integrated engineering solutions to complex process issues.

Customers rely on Westpro for engineering expertise in:

- Process development for a variety of commodities and water treatment
- Process & plant design
- Stress & FEA analysis
- Computational Fluid Dynamics (CFD) analysis
- Equipment sizing
- Equipment design & manufacture
- Structural design
- Installation & commissioning
- Equipment auditing and service
- Process auditing and consulting

Westpro's engineering team utilizes a suite of design software in its project and R&D activities. These include SolidWorks, AutoCAD, RISA-3D and Staad.

Top Left: Counter-current decantation (CCD) section of a Westpro gold processing flowsheet
 Top Right: Tank stress analysis
 Bottom: MJC2436 Modular Jaw Crusher designed and modelled by Westpro engineers
 Opposite Page: Exploded view of a grinding mill bearing housing

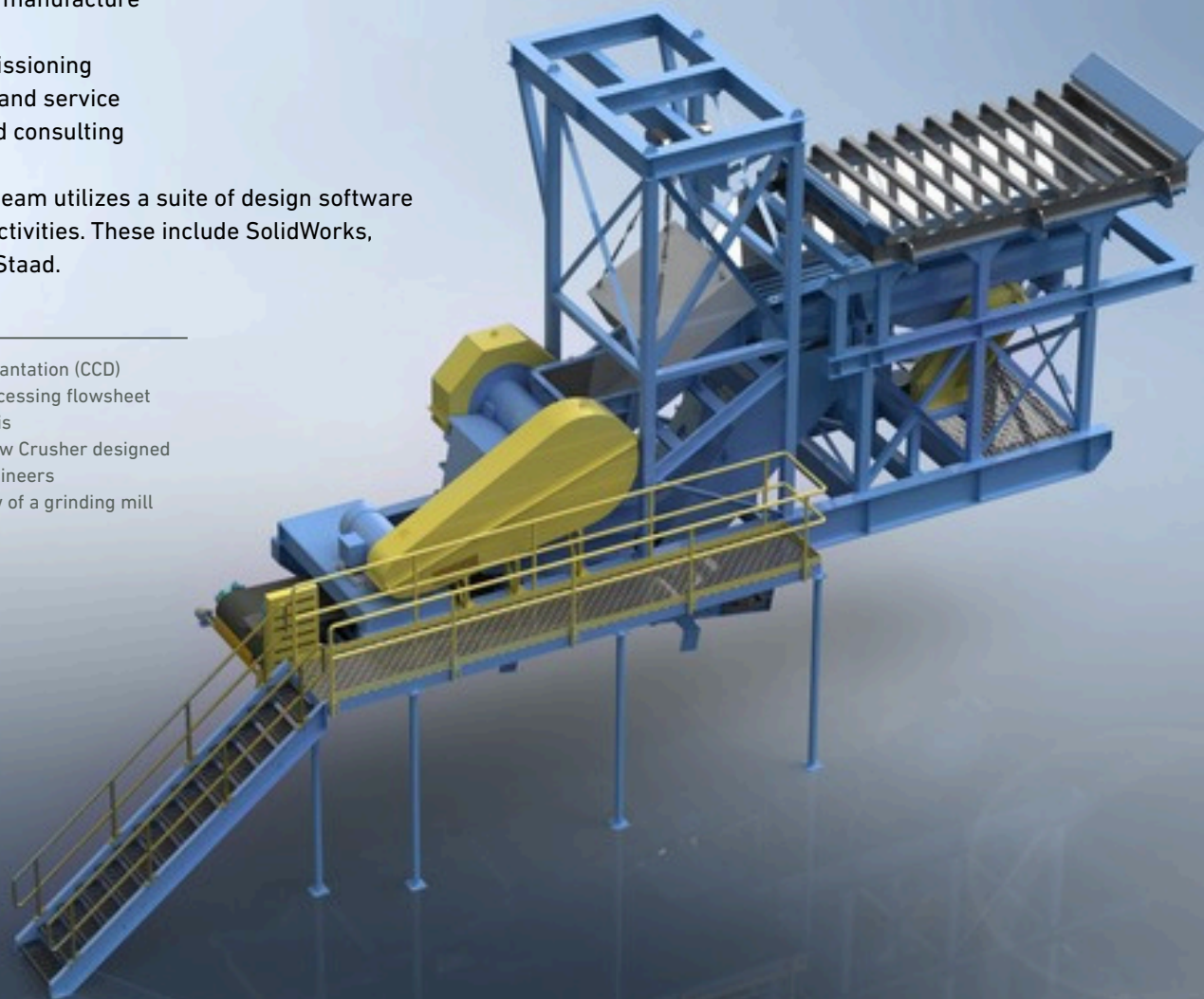

**WESTPRO HAS THE
ENGINEERING EXPERTISE TO
SUPPORT OUR CUSTOMERS IN
DEVELOPING INNOVATIVE AND
EFFICIENT SOLUTIONS**

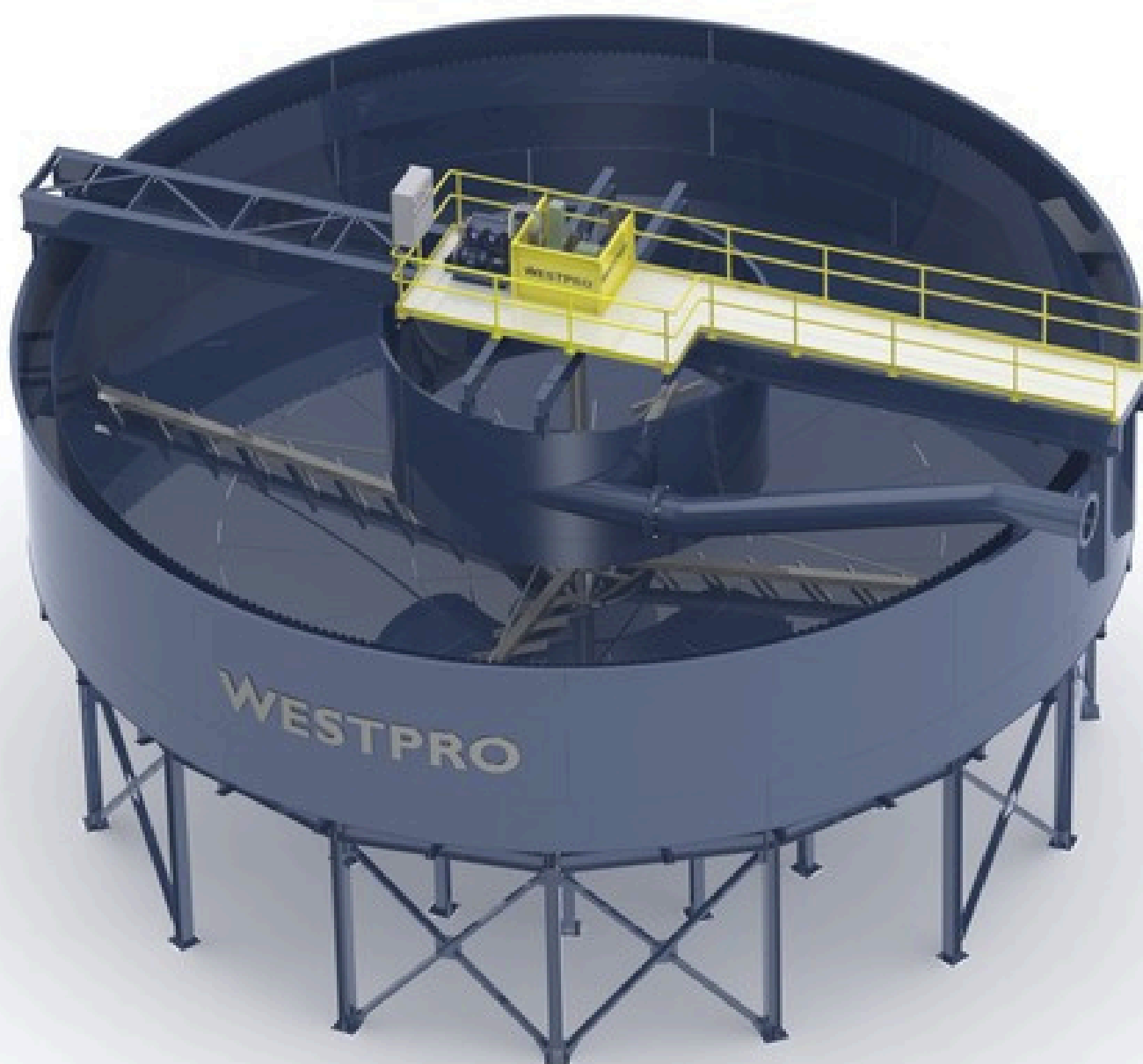

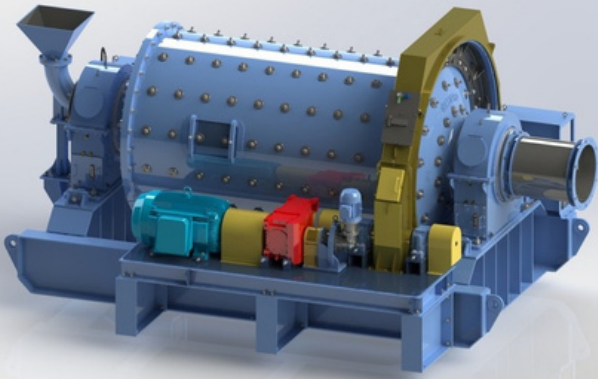

MODULAR PROCESS PLANTS

Utilizing industry-leading mineral processing expertise and integrated engineering capabilities, Westpro designs and manufactures turnkey modular processing plants that are tailored to meet site specific requirements and conditions. The plants combine unit operations from Westpro's comprehensive product line, along with auxiliary items, to offer customers a complete process technology solution.

System customization options include equipment designs, optimized plant layouts for efficient space utilization and the addition of auxiliary equipment as required. The modular plants are configured with a particular focus on ease of shipment, installation and operability. Westpro assembles and tests each module to the fullest extent possible prior to shipping, to ensure that every unit meets Westpro's quality standards.

Westpro's Modular Process Plants can include:

- Major process equipment
- Auxiliary equipment (such as wet scrubbers, blowers etc)
- Conveyors
- Pumps, piping and valves
- Instrumentation and control systems
- Motor Control Center (MCC) with electrical wiring
- Equipment support frames
- Access platforms, walkways, stairs and ladders



Top Left Left: 1.8m (6ft) diameter modular grinding mill with base frame
 Top Right: Modular 2-stage gold ore crushing system installed in British Columbia, Canada

Bottom: Turnkey Lime Slaking System designed to protect the lime feed solids from the moist and rainy conditions in Guyana

Opposite Page: Modular, turnkey base metals flotation plant installed in Spain



**MAXIMIZE YOUR ROI WITH
WESTPRO'S PURPOSE BUILT
MODULAR PROCESS PLANTS**





CRUSHING PLANTS

Westpro's modular crushing plants combine Westpro's line of Jaw and Cone Crushers with all required auxiliary equipment to accomplish the required size reduction. The plants are available in 1-, 2- or 3-stage crushing configurations.

Plant designs and layouts are developed to optimize conveyor arrangements and consolidate unit operations into modules where possible. Westpro's rigorous design approach minimizes CAPEX, OPEX, plant footprint and takes special consideration for ease of operation.

Westpro's scope for modular crushing plants may include (based on project requirements):

- Primary crusher (jaw crusher)
- Secondary & tertiary crushers (cone crushers)
- Vibrating screens
- Hoppers and fine ore bins
- Interconnecting conveyors and chutes
- Conveyor magnets, metal detectors and weigh scales
- Operator cab / control room
- Drives and lubrications systems

Top Left: MJC2436 Jaw Crusher Module, part of a 2-stage crushing plant

Top Right: 120TPH Modular 2-Stage Crushing Plant installed at a gold mine in British Columbia, Canada

Bottom: Modular 2-Stage Crushing System as supplied to a gold plant in Idaho, USA





GRINDING PLANTS

Westpro's mineral processing expertise is crucial in the design of grinding circuits to deliver superior comminution performance. The company's experienced team of process engineers analyze available application data to select key process parameters such as circulating load, type & size of mill and type of classification equipment.

Westpro's modular grinding plants consist of single or multiple grinding stages along with the associated classification circuit. The grinding stages utilize either Westpro's ball or rod mills, according to the application.

Westpro's scope for modular grinding plants may include (based on project requirements):

- Grinding mills (ball mill or rod mill)
- Classification circuit
 - Hydrocyclones
 - Vibrating screens
- Pump boxes
- Rod Chargers

Top: 1.5m (5ft) Modular BM58 Ball Mill built for a base metals mine in Manitoba, Canada

Bottom Left: 1.2m (4ft) diameter Rod Mill during freight to site

Bottom Right: Rod Charger designed to feed grinding rods to a 2.1m (7ft) diameter Rod Mill, on-site in Saskatchewan, Canada





FLOTATION PLANTS

Westpro's mineral processing expertise with a wide range of commodities is a significant advantage for our customers in the design of the key flotation section of mineral processing plants.

Westpro has the capability to design and manufacture turnkey modular flotation circuits that deliver excellent flotation performance. The design of each circuit is customized in terms of cell sizes, configurations and layout based on the available flotation testwork data. Utilizing either conventional flotation machines, tank cells, flotation columns or a combination of the three, Westpro can deliver high quality modular flotation solutions for any project scale.

Westpro's scope for modular flotation plants may include (based on project requirements):

- Flotation Machines for Rougher, Cleaner, Scavenger duties
 - Conventional flotation machines
 - Tank cells
 - Flotation columns
- Vibrating screens
- Hoppers and fine ore bins
- Conditioning tanks
- Reagent mixing and dosing systems
- Flotation air blowers

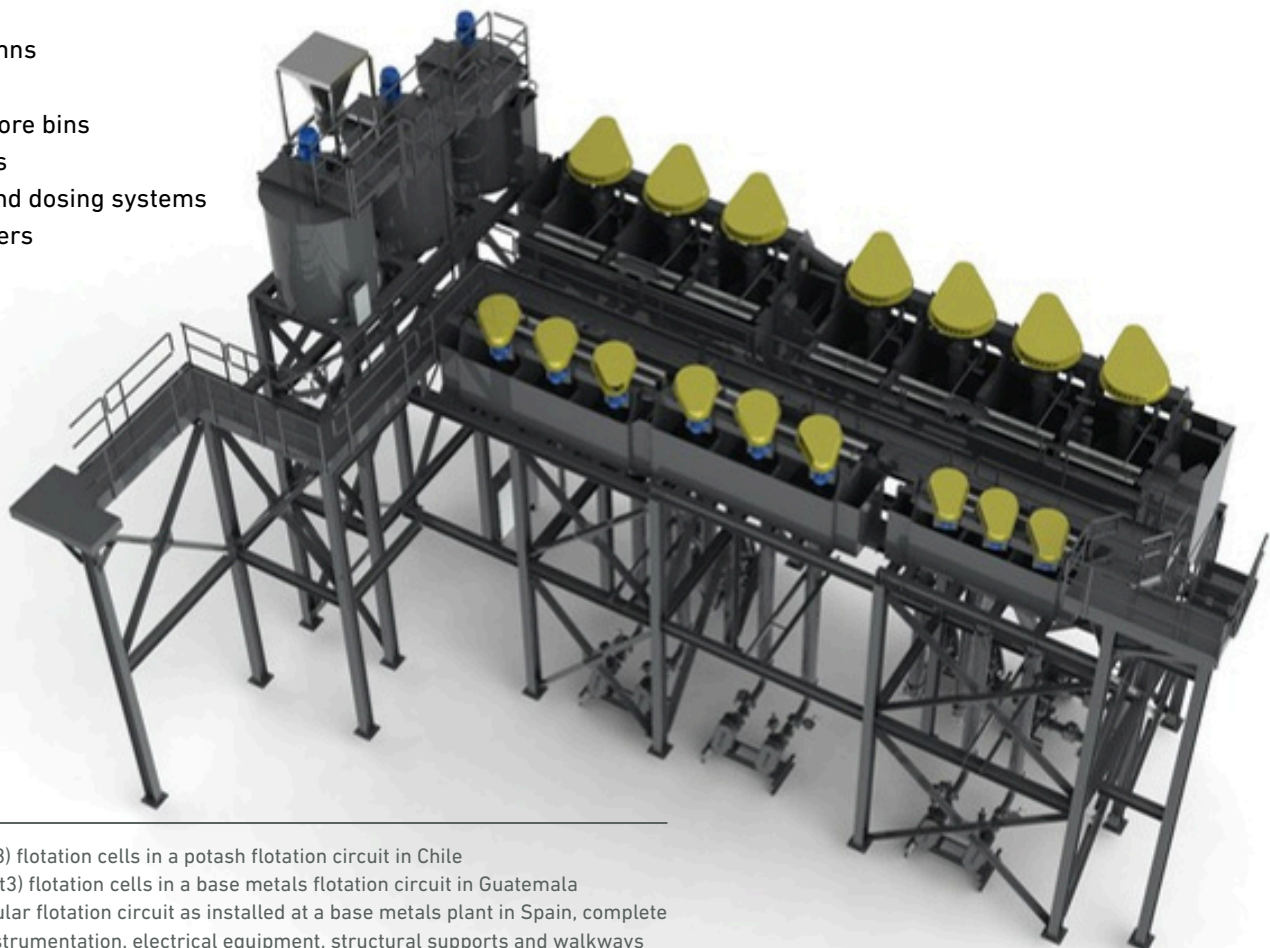

Top Left: 8.5m³ (300ft³) flotation cells in a potash flotation circuit in Chile
 Top Right: 5.7m³ (200ft³) flotation cells in a base metals flotation circuit in Guatemala
 Bottom: Turnkey, modular flotation circuit as installed at a base metals plant in Spain, complete with pumps, piping, instrumentation, electrical equipment, structural supports and walkways



DEWATERING PLANTS

Westpro's modular dewatering systems bring together one or all of the company's thickener, filter and dryer lines in a complete dewatering package.

The selection of the dewatering equipment combination is made by Westpro engineers based on test-work data, specifications and requirements of each project. With a filter, the product moisture can be reduced to below 10%wt. water while using a rotary dryer can reduce the product moisture to below 1%wt.

Westpro's scope for modular dewatering plants may include (based on project requirements):

- High Capacity Thickeners or Clarifiers
- Filters
 - Disc filter
 - Filter press
- Rotary Dryer
- Dust control equipment
- Dust control equipment

Top: 1.5m (5ft) Modular BM58 Ball Mill built for a base metals mine in Manitoba, Canada

Bottom Left: 1.2m (4ft) diameter Rod Mill during freight to site
 Bottom Right: Rod Charger designed to feed grinding rods to a 2.1m (7ft) diameter Rod Mill, on-site in Saskatchewan, Canada





HEAP LEAP ORE PREPARATION

Westpro has the expertise to design and manufacture turnkey process systems for the preparation of run-of-mine ore for heap leaching.

The systems combine the company's modular crushing plants and rotary drum Agglomerator lines along with auxiliary equipment. This gives customers a one source solution for run-of-mine ore preparation from the ROM bin all the way up to the ore heap. Westpro's Heap Leach Ore Preparation Systems can be used for a variety of commodities including gold, silver, uranium and copper.

Westpro's scope for modular heap leach systems may include (based on project requirements):

- Modular crushing plant
- Agglomerators
- Reagent silos for cement, quicklime and other reagents
- Aqueous reagent make-up and dosing systems

Top Left: 2.4m (8ft) diameter chain drive Agglomerator on-site at a copper heap leach operation in Peru

Top Right: 700MTPH capacity Modular Jaw Crusher installed at a copper mine in Yukon, Canada

Bottom: Two (2) 3.0m (10ft) diameter chain drive Agglomerators during installation at a gold heap leach operation in Mexico





TAILINGS MANAGEMENT SYSTEMS

The processing and storage of mine tailings is a key environmental issue for mining projects around the world. Utilizing its expertise in slurry dewatering technologies, Westpro offers turnkey Tailings Management Systems that allow owners to reduce or eliminate costly tailings ponds by producing stackable tailings.

These systems utilize combinations of the company's line of dewatering equipment to reduce the volume of the tailings slurry produced by the mill. An added benefit is the recovery of water for reuse in the process or elsewhere around the site.

Westpro's scope for tailings management system may include (based on project requirements):

- High capacity clarifier or thickener
- High density underflow (HDU) thickeners
- Flocculant mixing system
- Filter press or belt filter
- Agitated tanks for clarifier feed to filter feed

Top: View inside the tank of the 42m (138ft) High Capacity Thickener during installation at a potash processing plant in Saskatchewan, Canada

Bottom Left: 12.2m (40ft) elevated High Density Underflow Thickener and 7.9m (26ft) elevated High Capacity Thickener during installation at a nickel concentrator in Ontario, Canada

Bottom Right: Agitated reagent mixing and preparation tanks complete with support structure at a wastewater treatment plant in Minnesota, USA

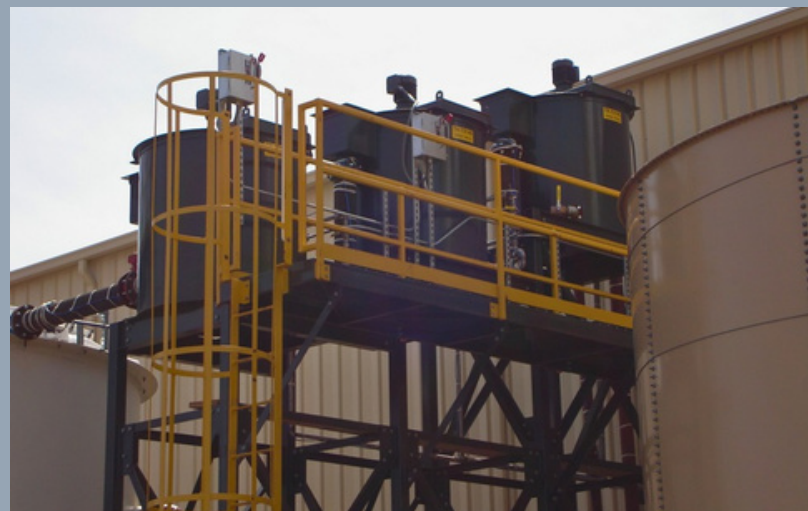

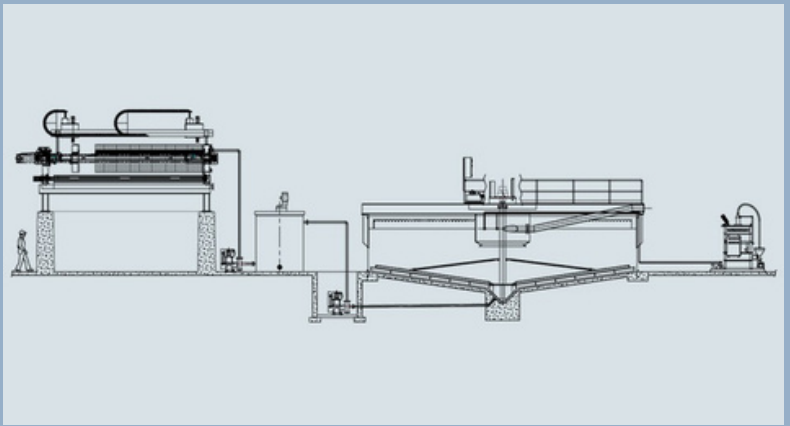
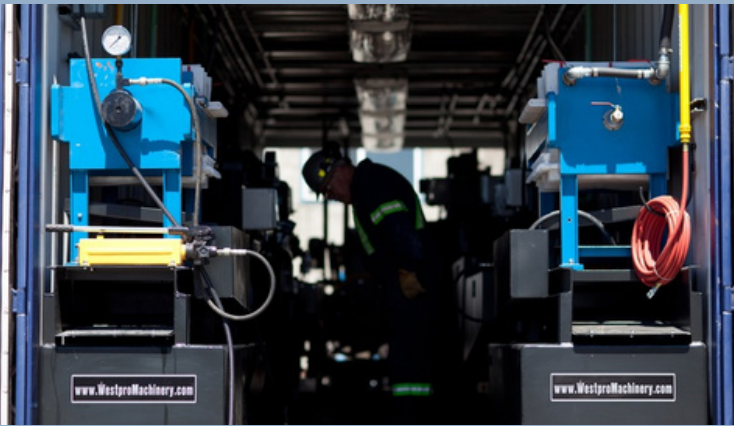

FINE REMOVAL SYSTEMS

Westpro's Fines Removal Systems provide an efficient solution for the removal of fine particulate solids from aggregate waste streams, eliminating the need for space- and labour-intensive settling ponds as well as providing reusable process water.

Westpro's fines removal systems combine the company's line of high performance dewatering equipment in the optimum combination for each project. The systems are purpose-built for each plant with equipment selection and design based on the results of settling and filtration testwork.

Westpro's scope for fines removal systems may include (based on project requirements):

- High capacity clarifier or thickener
- Flocculant mixing system
- Filter press or belt filter
- Agitated tanks for clarifier feed to filter feed

Top Left: Filter Presses as part of a Westpro 500kg/h containerized pilot plant
Top Right: Elevation view of a typical Westpro Fines Removal System complete with clarifier, flocculant mixing system, agitated tanks, filter press, pump and all auxiliary equipment
Bottom: 18m (60ft) diameter High Capacity Thickener on-site in Quebec, Canada





PILOT AND DEMONSTRATION PLANTS

Westpro's modular pilot and demonstration plants offer turnkey solutions for both major and junior mining companies to demonstrate project viability and prove new process technology. Customers rely on Westpro's mineral processing expertise in the development of creative solutions to the issues that arise during implementation of new technologies.

Westpro offers its customers a turnkey solution from concept to installation and on-site operation. In addition to the company's comprehensive range of pilot and demonstration scale process equipment, these plants include piping, instrumentation, process control, electrical and structural components. The flexibility to tailor each plant to project specific requirements is a key factor that differentiates Westpro from the competition.

Depending on the equipment sizes, Westpro's pilot and demonstration plants can be 'containerized' to fit into sea containers. This involves a focus on optimized equipment sizing and compact plant layout design. The advantages of containerized plants are the ease of transport, ease of set-up and portability between different mine sites.

Top: Inside view of the wet process container, part of a 500kg/h containerized pilot plant designed to process gold ore

Bottom Left: 10TPD Modular Demonstration Plant with grinding circuit, rougher flotation and CCD circuit on-site at a gold mine in Nevada, USA

Bottom Right: Feed hopper and 0.9m (3ft) diameter Ball Mill on-site in Nevada, USA, part of a 10TPD Modular Demonstration Plant





WATER & WASTEWATER TREATMENT

Westpro's expertise in water and wastewater treatment is rooted in over three decades of working with a variety of stakeholders in both industrial and municipal projects in the industry. This insight, combined with expertise in solid settling and solid-liquid separation technologies, ideally positions Westpro to deliver high performance process technology solutions to the industry.

Westpro's water and wastewater treatment equipment is purpose-built for the demands of the industry, while retaining the Westpro hallmarks of reliability and quality.

Westpro's line of water and wastewater treatment equipment can be used for a significant number of unit operations in the wastewater treatment process, from the screening out of large suspended solids to the removal of fine solids in a secondary circular clarifier. Multiple equipment units can be combined to provide a modular process solution for sections of the treatment plant.

Westpro's line of water and wastewater treatment equipment includes:

- Circular Clarifiers
- Sludge Thickeners and Fermenters
- Filter Presses
- Bulk Chemical Preparation & Dosing Systems
- Flocculant Preparation & Dosing Systems
- Lime Slaking Systems
- Rotary Trommels

Top Left: 8.2m (27ft) diameter wastewater treatment clarifier with centre-pier drive, on-site in British Columbia, Canada

Top Right: 2.4m (8ft) diameter reagent silo during freight to site

Bottom: 17.5m (58ft) diameter sludge fermenter at a wastewater treatment plant in British Columbia, Canada



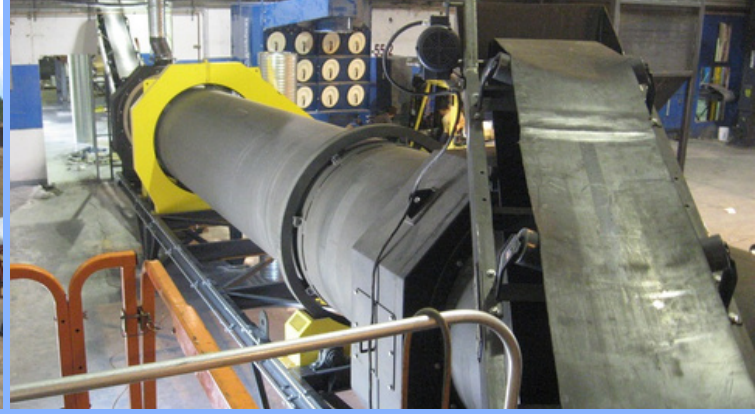

AGGREGATES PROCESSING

The aggregates and frac sands processing industry has made up a key component of Westpro's business since the company's inception in 1985. Westpro applies its expertise in crushing, grinding, material scrubbing and dewatering to develop cost-effective and reliable process technology solutions custom-configured to the demands of the aggregate industry.

Westpro's aggregate product line can cover the entire unit operation range for certain aggregate plants. Westpro possesses the industry expertise to combine these products into a modular plant, providing its customers a complete turnkey solution.

Westpro's aggregate processing product lines include:

- Agitators
- Attrition Scrubbers
- Cone crushers
- Clarifiers
- Filter Presses
- Flocculant Preparation & Dosing Systems
- Grinding Mills
- Hopper Feeders
- Jaw crushers
- Rotary Dryers
- Rotary Trommels
- Flat-bottom Thickeners
- Portable Crushers and Crushing Systems

Top Left: 700TPH capacity Modular Jaw Crusher on-site at an operation in Yukon, Canada
Top Right: 1.2m (4ft) diameter Rotary Dryer at an industrial sands processing plant in Louisiana, USA
Bottom: Westpro 4-cell AS56VB-4 Attrition Scrubber at a frac sands processing plant in Texas, USA





HOPPER FEEDERS

Available as stationary, modular and portable units, Westpro's heavy duty Hopper Feeders are suitable for any scale of mining or aggregate project.

- Capacities of up to 100 tons
- Top dimensions customizable to client's loader bucket
- Abrasion resistant lining available
- Stationary or hydraulically actuated tilting grizzly available
- Designed to promote material flow through hopper and minimize hold-up
- Belt or screw feeder options available
- VFDs available for feeder drives to control material feed rate
- Option for magnetic separation capabilities
- Portable units include complete road-worthy chassis assembly
- Portable units include hydraulic power units to eliminate the need for electrical power in the field

ADAPTABLE TO ANY TEMPORARY SOLID STORAGE APPLICATION

Top Left: Modular 2 ton capacity hopper with screw feeder
 Top Right: Portable 5 ton capacity hopper feeder with magnetic separation at the Westpro production facility
 Bottom: 35 ton capacity hopper feeder with hydraulically tilting grizzly





JAW CRUSHERS

Westpro's heavy duty jaw crushers are available as standalone units, modular assemblies, portable assemblies and as part of modular crushing plants. Generally used as primary crushers, these mine-duty jaw crushers provide excellent coarse material crushing performance in the mining and aggregate industries.

- Capacities of up to 1,000 tons per hour
- Bolttable frame for larger crushers eliminates stress issues and allows for transportation in pieces
- Spherical self-aligning roller bearings designed ease of maintenance
- Large eccentric throw with a steep toggle angle to magnify the effective stroke
- Reversible manganese jaw plates for long life
- Hydraulic closed side setting (CSS) adjustment system also effective in clearing crusher cavity
- Shock absorbing discharge mechanism
- Automatic lubrication systems available

Top: MJC2436 Modular Jaw Crusher with feed hopper, vibrating grizzly and discharge conveyor at the Westpro Production facility

Bottom Left: 1000mm (40in) x 1250mm (50in) Jaw Crusher supplied to a diamond mine in Quebec, Canada

Bottom Right: 250mm (10in) x 750mm (30in) Portable Jaw Crusher with foldable discharge conveyor





CONE CRUSHERS

Westpro's high productivity cone crushers are available as standalone units, modular assemblies, portable assemblies and as part of modular crushing plants. The robust design of these crushers makes them an ideal option for fine crushing applications in the mining and aggregate industries.

- Available in up to 500HP (370kW) units
- Large eccentric with high rotation speed
- Exclusive self-tightening mantle and concave
- Hardened and tempered chrome molybdenum eccentric shaft
- Feed plate designed for even material distribution
- Supplied complete with hydraulic system
- Automatic hydraulic chamber adjustment
- Option for automatic hydraulic or spring discharge clearing device for easy tramp iron release
- Automated lubrication system
- Heavy duty v-belt drive on adjustable motor base



APRON FEEDERS

Westpro's mine-duty Apron Feeders are designed to thrive in the toughest mineral processing environments. Manufactured with robust, wear resistant components, these feeders are suitable for ore bin withdrawal and stockpile reclaim duty.

- Heavy duty true crawler type tractor design
- Sizes up to 2.4m (8ft) wide
- Fabricated mild steel frame
- Full length impact rails to limit pan deflection
- Cast manganese steel alloy overlapping pan design for impact and abrasion resistance
- Dual tractor type chain
- Upper carry and return rollers with lifetime lubricated seals
- Effective take-up system
- VFDs available for close control of feed rate

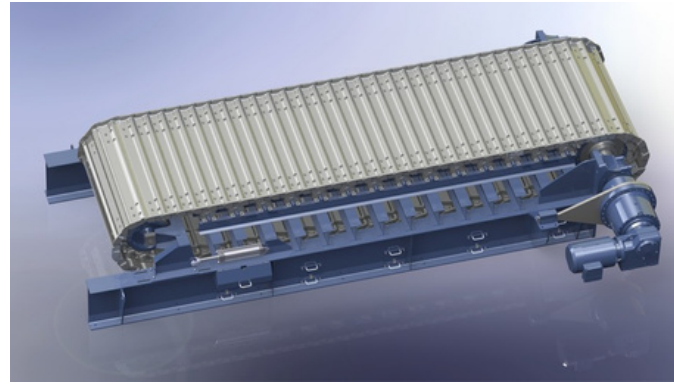

AGITATORS

Customized engineered for each application, Westpro's Agitators provide reliable and energy efficient performance in challenging slurry applications.

- Proven performance in solids suspension, blending and dispersion applications
- Heavy duty design for abrasive slurry applications
- Wide range of available sizes, suitable for projects ranging from mega-scale mining projects to pilot plants
- Bridge mounted agitator drives
- Designed for easy integration onto Owner's tanks
- Heavy duty tanks available in bolted or welded construction
- Numerous impeller options available to suit application
- Custom materials and linings to handle corrosive or high abrasive products

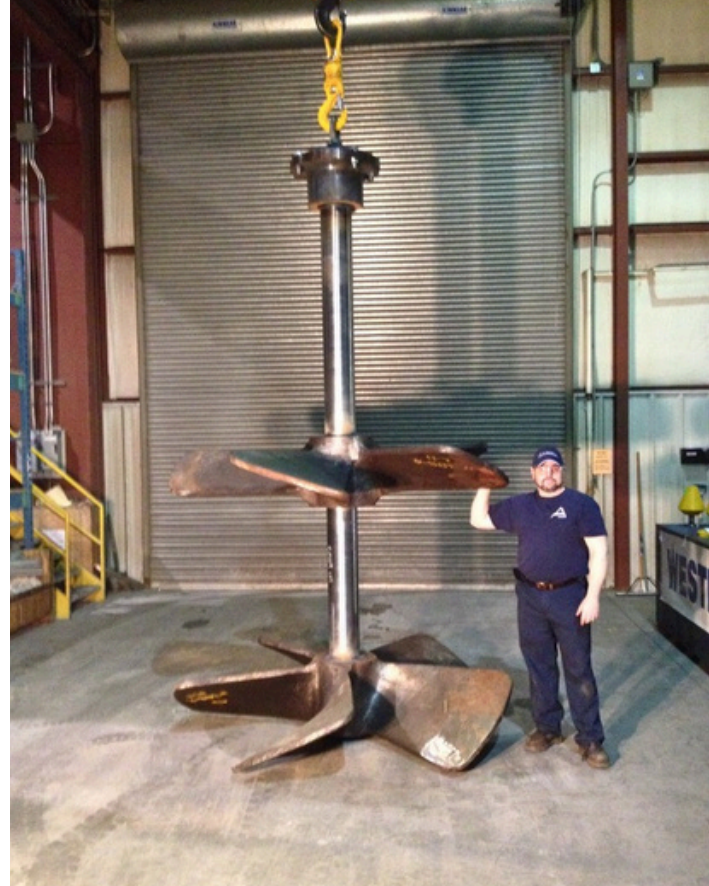

Opposite Page

Top Left: CC200HPH high performance Cone Crusher with 200HP drive motor and modular base frame

Top Right: MCC1300-616 Modular Cone Crusher at a gold process plant in British Columbia, Canada

Bottom: MCC300HPH high performance Cone Crusher with 300HP drive motor and modular base frame, designed for a gold process plant in Idaho, USA

This Page

Top: 1.8m (6ft) wide mine duty AF620 Apron Feeder

Bottom: Dual impeller agitation mechanism with 2030mm (80in) diameter propellers

AGGLOMERATORS

Westpro's heavy duty agglomerators have delivered proven performance in crushed ore agglomeration improving heap leach recoveries in mining applications. Also used as mixing or tumbling drums, Westpro agglomerators are custom configured to meet the demands of each application.

**PROVEN IN MINING
HEAP LEACH
OPERATIONS**

- Robust construction for tough mining environments
- Sizes ranging from 0.9m (3ft) diameter to 4.6m (15ft) diameter
- Up to 350HP (260kW) drives
- Drive options to suit customer preference
 - Chain drive
 - Tire drive
 - Gear drive
- Rubber lined for wear and abrasion protection (other lining options available)
- Drum internal lifter bars to gently agitate material and promote agglomeration
- Fully customizable with options such as additional spray bars, drum scraper bars and more
- Designed to integrate with optional auxiliary equipment such as exhaust gas scrubbing systems

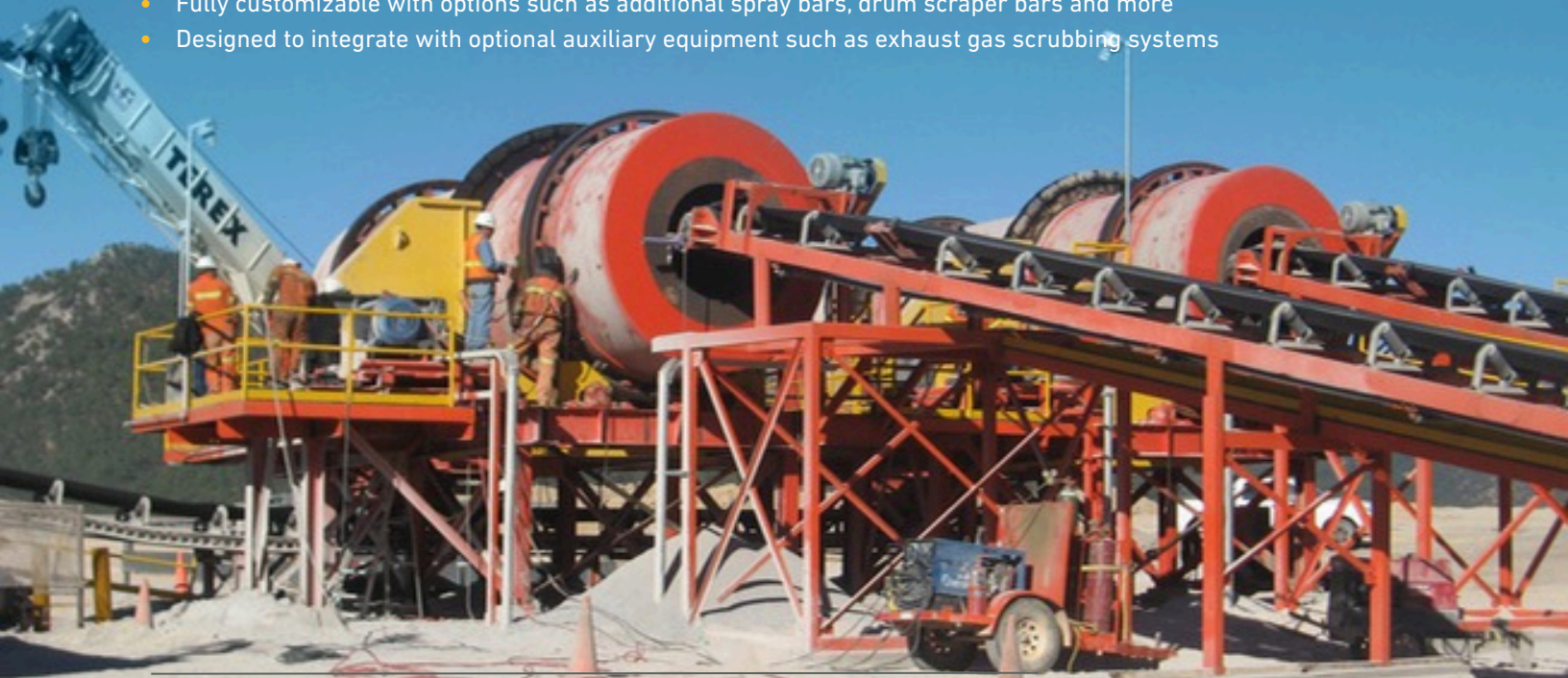

Top: Two (2) 3m (10ft) diameter chain drive Agglomerators at a gold heap operation in Mexico
Bottom Left: 2.4m (8ft) diameter chain drive Agglomerator at a gold heap leach operation in Mexico
Bottom Right: 2.4m (8ft) diameter tire drive Agglomerator at a copper heap leach operation in Mexico





GRINDING MILLS

Westpro's heavy duty grinding mills are designed for durability and excellent grinding performance in mining applications.

- Sizes up to 4.9m (16ft) diameter and 4000HP (2980kW)
- Available with rubber, steel or ceramic liners
- Fabricated or cast heads with integral trunnions
- Spur, single or double helical gear and pinion set, designed for long life
- Automated pressure lubrication system
- Mills 2.7m (9ft) diameter and below can be mounted on modular frames
- Many feed and discharge options
- Options available for mill jacking systems and inching drives
- Also available in batch configuration

**BUILT TO THRIVE
IN THE TOUGHEST
MINERAL PROCESSING
ENVIRONMENTS**

Top: 1.8m (6ft) diameter Ball Mill and Rod Mill with modular frames, designed for a gold processing plant in Idaho, USA

Bottom Left: 2.1m (7ft) diameter Rod Mill at a potash processing plant in Saskatchewan, Canada

Bottom Right: 0.9m (3ft) diameter Batch Ball Mill drum at the Westpro Production Facility



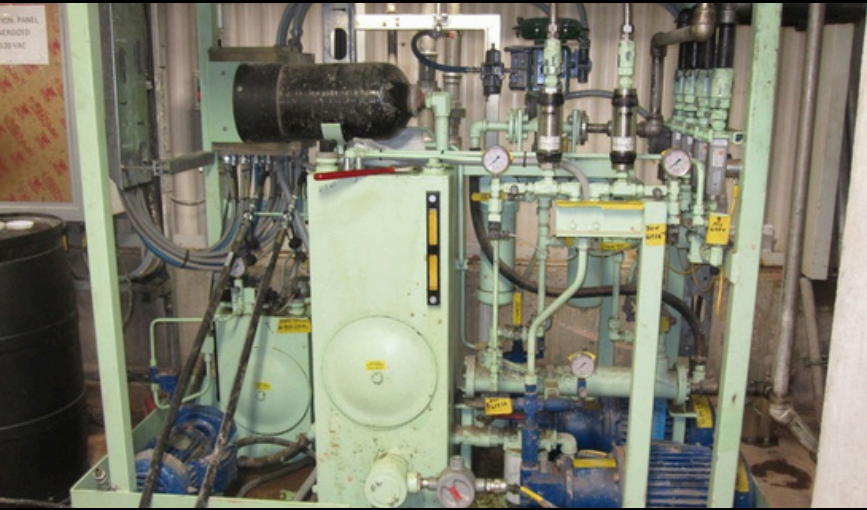

GRINDING MILL ACCESSORIES

In addition to grinding mills, Westpro offers its customer a range of mill accessories to facilitate efficient use and ease of operation.

Rod Chargers

- Undercarriage with integrated forklift rails for transport
- Hydraulically actuated rod indexer can be configured to accept varying rod diameters
- Hydraulically actuated rod carrier
- Nosing idler to prevent nose diving
- Local control panel with PLC
- Integrated adjustable height operator platform to allow for safe viewing into mill
- Rack includes rod wear strips

Inching Drives

- Large reduction for ease of mill maintenance
- Kirk key interlocks and guards for operator safety

Jacking Systems

- Jacking cradles to lift and support mill during erection and maintenance
- Hydraulic unit with remote foot pedal operation

Automatic Lubrication Systems

- Fully automated for trunnion and pinion bearing lubrication
- Includes all required instrumentation and controls



ATTRITION SCRUBBERS

Westpro's versatile attrition scrubbers provide efficient slurry scrubbing solutions for applications in a variety of industries including mining, frac sands, aggregates and soil remediation. The scrubber tanks and mechanisms are designed to produce intense agitation and deliver superior scrubbing performance.

- Capacities ranging from 0.008m³ (0.3ft³) to 165m³ (5,800ft³)
- Available in 2-, 4- or 6-cell configurations
- Opposing axial turbine propellers provide extreme mixing power
- Efficient scrubbing solution for high density feeds
- Engineered baffles to effectively direct pulp flow
- Rubber lined for wear protection. Tile lining option available
- Designed for easy drive removal for quick maintenance

**WESTPRO
MANUFACTURES
SOME OF THE WORLD'S
LARGEST ATTRITION
SCRUBBERS**

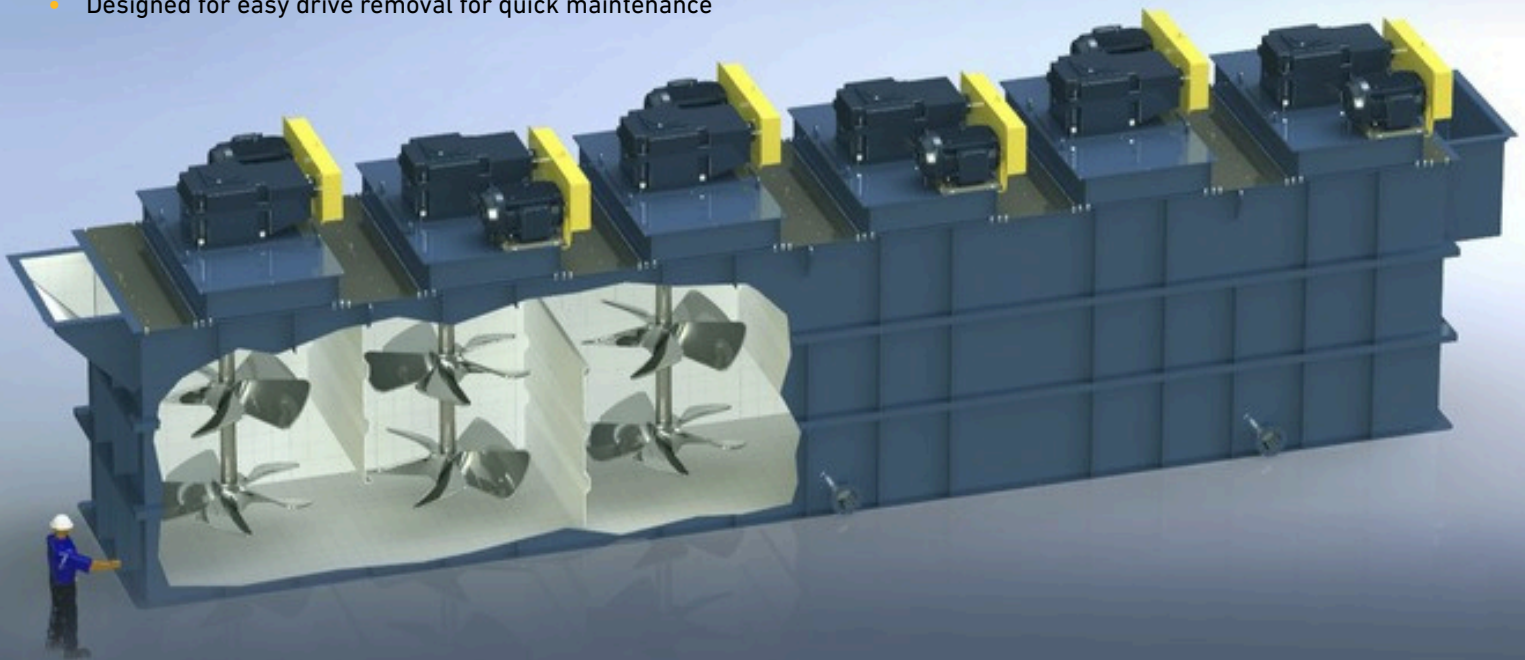

Opposite Page:

Top Left: Automatic lubrication system for a 2.1m (7ft) diameter grinding mill

Top Right: Inching drive as designed and supplied for a 1.8m (6ft) diameter grinding mill

Bottom: Rod Charger during testing at the Westpro Fabrication Facility

This Page:

Top: 165m³ (5,800ft³) capacity 6-cell AS108VBH-6 attrition scrubber with tile lining, as installed at a potash processing plant in Saskatchewan, Canada

Bottom Left: 11.4m³ (400ft³) capacity 2-cell AS64DD-2 attrition scrubber with direct drive at the Westpro Production Facility

Bottom Right: 60m³ (2,100ft³) capacity 6-cell AS80VBH-6 attrition scrubber tank during installation at a potash plant in Saskatchewan, Canada





DRUM SCRUBBERS

Designed to maximize solid particle contact scrubbing performance, Westpro's heavy duty Drum Scrubbers are ideal for solids scrubbing applications in the mining and aggregate industries.

- Sizes ranging from 0.9m (3ft) diameter to 4.6m (15ft) diameter
- Drive options to suit customer preference
 - Chain drive
 - Tire drive
 - Gear drive
- Rubber lined for wear and abrasion protection (other lining options available)
- Lifter bars designed to promote solid particle contact and scrubbing
- Modular frame option available for drum mounting.

ROTARY TROMMELS

Westpro's Rotary Trommels are available as both modular and portable units, providing the flexibility to meet the need of various screening applications in the mining and aggregate industries.

- Heavy duty construction
- Support rollers and thrust wheel assemblies
- Polyurethane screen panels. Options available for alternative screen materials
- Replaceable screen panels via bolted connections to skeleton frame
- Tire drive or chain drive options available
- Includes feed, oversize and product chutes
- Option for dust cover over trommel screen
- Foldable discharge conveyor provided for portable trommels



Top Left: 2.4m (8ft) diameter tire-driven rotary drum unit
 Top Right: 1.8m (6ft) diameter Rotary Trommel at the Westpro Production Facility
 Bottom: 1.8m (6ft) diameter Rotary Trommel at a gold processing plant in the Dominican Republic



FLOTATION MACHINES (CONVENTIONAL)

Utilizing the company's wealth of experience in the mineral processing industry, Westpro's flotation machines are designed for efficient and optimal performance in all mineral flotation applications (gold, base metals, potash, lithium and more).

Conventional Flotation Cells

- Cell capacities ranging from 0.01m³ (0.5ft³) to 17m³ (600ft³)
- Available in custom layout configurations to meet the required flotation residence time
- Mechanisms specifically designed for optimized pulp-air mixing and pulp suspension
- Engineered baffles reduce pulp short-circuiting and enhance pulp-air mixing
- Complete cell lining system for wear and abrasion protection including lining of impeller and diffuser
- Froth paddles and launders available as options
- Automatic cell level control system with ultrasonic sensors and dart valves

Top: Lithium flotation circuit with Westpro Conventional Flotation Machines, installed in Quebec, Canada
 Bottom Left: 8.5m³ (300ft³) Conventional Flotation Machines, part of a potash flotation circuit in Chile
 Bottom Right: 5.7m³ (200ft³) Conventional Flotation Machines at a base metals processing plant in Guatemala





FLOTATION TANK CELLS

Developed through an extensive R&D process, Westpro's Flotation Tank Cells deliver industry-leading flotation performance in a variety of mineral processing applications. In addition to an optimized mechanism design, the Flotation Tank Cells include a number of features to facilitate operation and maintenance with a view to maximizing plant productivity.

Flotation Tank Cells:

- Cell capacities ranging from 14m³ (500ft³) to 300m³ (10600ft³)
- Rotor/Stator design provides
 - Excellent pulp suspension
 - Superior bubble contact
 - Enhanced bubble generation
- Robust bevel/helical drive with direct air connection, designed specifically for Westpro flotation tank cells
- Easy access drive guards allow simple adjustment of rotor speed for optimization of the performance of each cell
- Foldable froth crowder allows for quick removal of shaft and rotor
- Automatic cell level control system with ultrasonic sensors and dart valves
- Customized launder designs

ROTOR/STATOR DESIGN OPTIMIZED FOR FLOTATION USING CFD TECHNOLOGY

Top Left: 14m³ (500ft³) Flotation Tanks during freight to site
 Top Right: Cutaway view of Westpro Flotation Tank Cell showing foldable froth crowder and easy mechanism replacement
 Bottom: Bank of 130m³ (4600ft³) Flotation Tank Cells, as delivered to a mine in Mexico

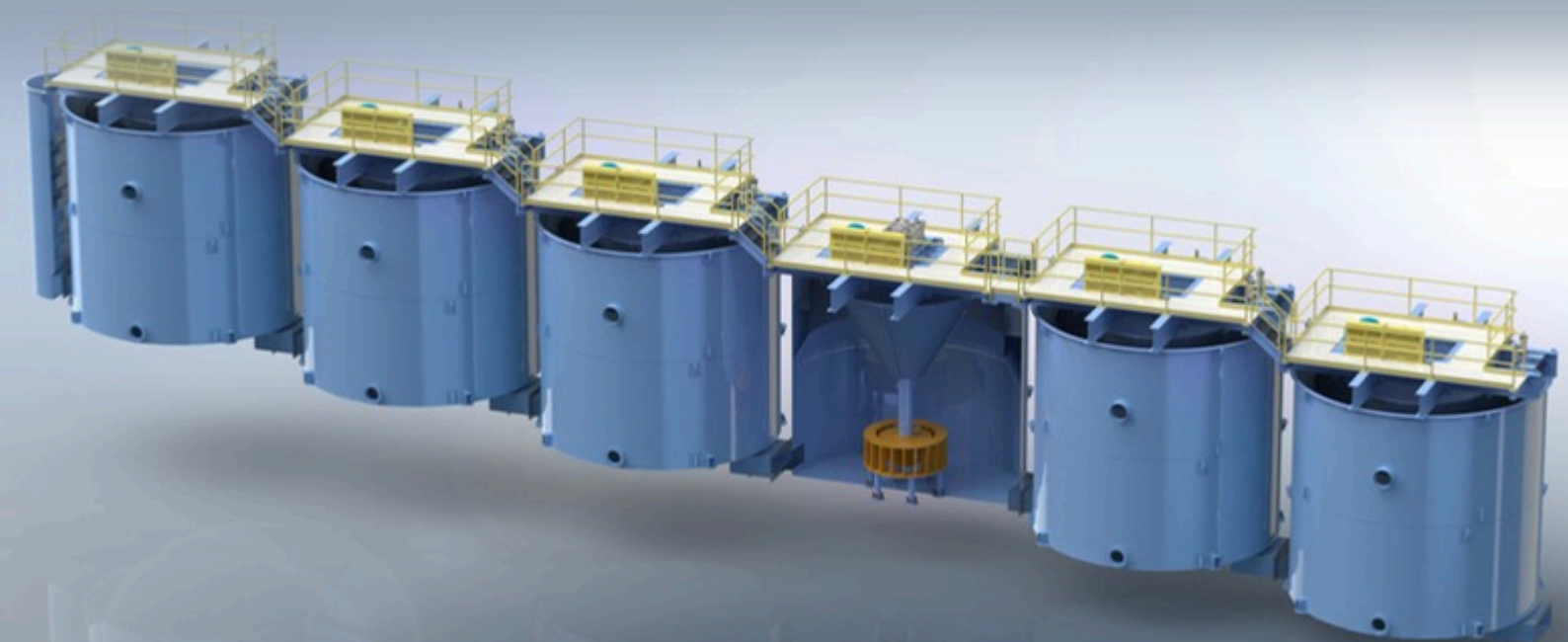



THICKENERS

Equipped with new generation hydraulic drives and low drag-high capacity rakes, Westpro's thickeners deliver superior solids settling performance. The robust construction of the thickeners ensures superior performance in high-torque applications.

- Various thickener designs:
 - Conventional
 - High Capacity/High Rate
 - High Density Underflow (HDU)
 - Wastewater treatment
- Various tank construction options
- Low drag-high capacity rakes
- Specially engineered, high performance feed well designs for enhanced solids settling
- Options available for floc contactors and auto-dilution
- New generation hydraulic drive with high torque capability
- Integrated rake lift drive base with high capacity hydraulic cylinders
- Single hydraulic power unit powers both drive and rake lift
- Automatic rake lift system with pressure switch torque alarms
- Local control panel and PLC

**OPTIMIZED TO DELIVER
SUPERIOR SOLID
SETTLING PERFORMANCE
THROUGH EXTENSIVE R&D**

Top: 42m (138ft) diameter elevated High Capacity Thickener at a potash plant in Saskatchewan
 Bottom Left: 18m (60ft) diameter High Capacity Thickener at a silver processing plant in Mexico
 Bottom Right: New generation Westpro hydraulic drive, for a 42m (138ft) diameter thickener





CLARIFIERS

Westpro's Clarifiers have delivered proven wastewater treatment performance in both municipal and industrial applications.

- Various clarifier design option
 - Bridge-mounted drive
 - Centre-pier drive
 - Reactor (Solids Contact) clarifier
- Various tank construction options
- Low drag-high capacity rake design
- Advanced feed well designs to enhance material settling performance
- Hydraulic drive system specifically designed for wastewater applications
- Available options include scum collection devices, sludge withdrawal rings and enhanced instrumentation & control systems
- Electric drive option available



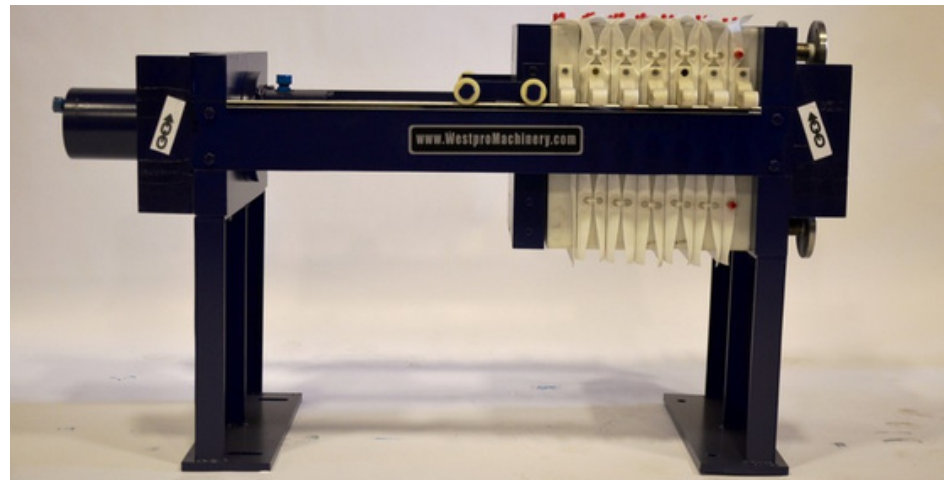
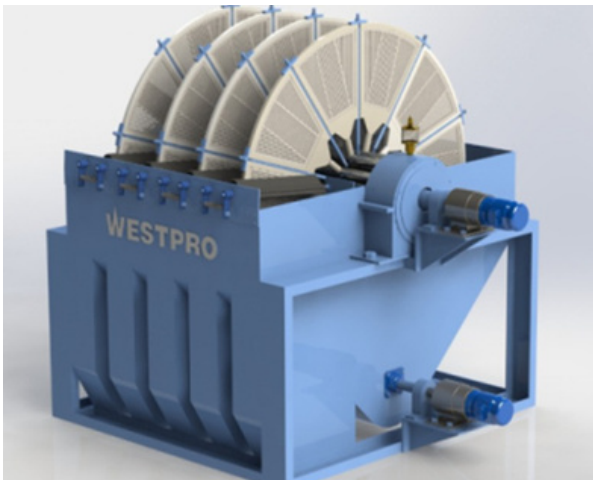

DISC FILTERS

Westpro's disc filters are versatile machines with applications in a variety of industries. The filters are supplied complete with all auxiliary systems to provide customers with a turnkey solution for their filtering needs.

- Sizes ranging from 1.2m (4ft) diameter to 3.8m (12.5ft) discs
- Heavy duty filter tank and center shaft construction
- Filter discs options available:
 - Polypropylene
 - Ceramic
- Disc scraper assembly
- Expandable filter capacity through addition of discs
- Bottom agitator for filter tank
- Complete with vacuum, air blow and filtrate handling systems

FILTER PRESSES

Westpro's filter presses are suitable for applications in wide variety of industries and are fully customized to the requirements of each customer. Each filter is designed to the customers preferred degree of automation and is supplied complete with all auxiliary equipment required for the filtration process.

- Side bar type horizontal filter presses
- Polypropylene filter plates
- Expandable filter capacity through addition of plates
- Sizes from 400mm x 400mm to 2000mm x 2000mm filter plates
- Recessed and membrane type plates available
- Automatic, semi-automatic and manual filter configurations available to suit site requirements
- Bomb-bay doors
- Plate shifter with shaking capabilities
- Filter manifold with all required valves for feed, filtrate and air
- Filtrate, cake wash and cloth wash systems available
- Special materials available for applications with aggressive chemicals

Opposite Page:

Top Left: 8m (26ft) diameter CL26 Clarifier at a wastewater treatment plant in British Columbia, Canada

Top Right: Westpro Centre-Pier Clarifier drive, design for clarifiers up to 73m (240ft) in diameter

Bottom: 27m (90ft) diameter CL90 Clarifier with concrete tank at a wastewater treatment plant in British Columbia, Canada

This Page:

Top Left: 1.8m (6ft) diameter Disc Filter with four discs

Top Right: Mine duty manual Filter Press with 470mm x 470mm plates



ROTARY DRYERS

Custom designed for each application, Westpro's Rotary Dryers deliver efficient and cost-effective drying performance.

- Dryer sizes range from 0.6m (2ft) diameter to 2.7m (9ft) diameter
- Designed for high temperature drying applications
- Drive options to suit applications
 - Chain drive
 - Direct drive
 - Friction drive
 - Gear drive
- Specially forged riding rings and rollers ensure long-life and low maintenance operation
- Custom lifter configuration to optimize material drying
- Dryers can be mounted on concrete piers, portable frame or modular frame
- Available add-ons include refractory lined combustion chambers, burners and dust collection systems

FULLY ENGINEERED DRYER PLANTS WITH BURNER AND OFF-GAS TREATMENT SYSTEMS

Top Left: 1.4m (4.5ft) diameter RD5425 Rotary Dryer with stainless steel drum and friction drive at a chemical plant in British Columbia, Canada
Top Right: 1.2m (4ft) diameter RD428 Rotary Dryer at a garnet sand processing plant in Louisiana, USA
Bottom: 2.1m (7ft) diameter RD740DD Rotary Dryer with direct drive



REAGENT PREPARATION & DOSING SYSTEM

Westpro designs and manufactures turnkey modular Reagent Preparation & Dosing systems. These systems can be configured to handle both bulk chemicals and liquid reagents, and deliver them to the process at the desired solution strength.

- Wide range of capacities available
- Silos or bag-unloading hoppers for bulk chemical storage
- Drum pumps for liquid reagent tote unloading
- Heavy duty mixing tank and holding tank, as required
- Mixing tank agitator custom designed to deliver the required agitation flow patterns in each application
- Dosing pumps with VFDs to meter reagent to the process
- Piping, valves and instrumentation
- Local control panel with PLC
- Multiple reagent systems can be consolidated as a single module with required support structure
- System layouts fully customizable to suit available plant space

Top Right: 3.7m (12ft) diameter lime and soda ash storage silos, part of Westpro's Reagent Preparation and Dosing Systems at a wastewater treatment plant in Minnesota, USA
Bottom: Reagent mixing tanks with support structure at a wastewater treatment plant in Minnesota, USA





FLOCCULANT PREPARATION & DOSING SYSTEMS

Westpro's designs and manufactures turnkey modular Flocculant Preparation & Dosing Systems. These systems mix bagged dry flocculant powder with process water to produce a flocculant solution of the desired strength.

- Wide variety of capacities available
- Receiving hopper and volumetric screw feeder. Hopper is provided with bag breaker or bag discharge for larger units
- Eductor-blower system to pneumatically convey flocculant powder to the mixing tank
- Wetting head for initial contact of dry flocculant with water
- Heavy duty mixing tank and holding tank
- Mixing tank agitator designed for gentle mixing without damage to the expanded polymer
- Dosing pumps available with VFDs
- Local control panel with PLC

Top: Modular FMS25-4 Flocculant Mixing Systems during testing at the Westpro Production Facility

Bottom Left: Westpro modular Flocculant Mixing System FMS25-4 with mixing tank positioned above holding tank

Bottom Right: FMS25-4 flocculant hopper, screw feeder, eductor, blower assembly for flocculant conveying to the mixing tank





LIME SLAKING SYSTEMS

Fully customizable in terms of equipment supply, layout and site conditions, Westpro's Lime Slaking Systems offer an optimized, turnkey slaking solution for your project.

- Turnkey lime slaking systems
- Heavy duty construction for the mining and process industries
- Two slaker options
 - Detention type
 - Ball mill type
- Quicklime throughput capacities of up to 30 tons per hour
- Include quicklime silo or bag breaking hopper, slaker, grit removal system, hydrated lime holding tank
- Supplied complete with pumps, piping and instrumentation
- PLC controlled, automated process to ensure efficient and safe slaking

TURNKEY, FULLY CUSTOMIZABLE SLAKING SYSTEM DESIGNS

Top Left and Right: Detention Type Lime Slaking System including Quicklime Silo with storage capacity for 240 metric tonnes. Delivered and commissioned in Nevada, USA.

Bottom: Quicklime and soda ash storage silos (part of reagent preparation systems) at a wastewater treatment plant in Minnesota, USA





PORTABLE PROCESS EQUIPMENT

Westpro's line of portable process equipment is ideal for use in aggregate quarries, soil remediation projects and mining crushing systems. These self-contained units require no auxiliary equipment allowing for ease of operation in the field.

- Portable product lines include:
 - Portable Agglomerators
 - Portable Crushers (Jaw and Cone)
 - Portable Hopper Feeders
 - Portable Rotary Trommels
- Heavy duty, durable construction
- Easily transportable behind a 1 ton truck or tandem dump
- Quick setup
- High stacking foldable discharge conveyor
- Road-worthy design with complete chassis assembly
- Adjustable hydraulic levelling legs
- Hydraulic and diesel power units (optional) eliminate the need for electrical power in the field

SELF-CONTAINED UNITS, IDEAL FOR AGGREGATE QUARRIES AND REMOTE SITES

Top: 5 ton capacity feed hopper with foldable conveyor and magnetic separation, transported by a truck. Custom-designed for a foundry sands recycling application

Bottom Left: Westpro's diesel powered portable jaw crusher

Bottom Right: Portable Rotary Trommel with adjustable tilt angle and folding conveyor





PORTABLE CRUSHERS

Westpro's portable jaw and cone crusher units deliver self-contained crushing solutions for quarries, remote sites and construction projects. These crushers are available as stand-alone units and multiple units can also be combined into 2- or 3-stage portable crushing plants.

- Heavy duty, durable construction
- Quick setup
- Range of sizes available to meet different throughput requirements
- Include all auxiliary equipment such as hoppers, vibrating grizzly feeders, conveyors, vibrating screens as required for each unit
- Easily transportable behind a 1 ton truck or tandem dump
- Road-worthy design with complete chassis assembly
- Adjustable hydraulic levelling legs
- Hydraulic and diesel power units eliminate the need for electrical power in the field
- Easily converted to handle different products
- Can be converted to modular crushing units on-site

Top Left: Portable Jaw Crusher and Portable Cone Crusher modules converted to modular 2-stage crushing plant at a mine site in British Columbia, Canada
 Top Right: JC3840P Portable Jaw Crusher
 Bottom: Portable Cone Crusher Module with CC1300 Cone Crusher, vibrating screen, interconnecting conveyors and auxiliary equipment during freight to site





PILOT & LABORATORY EQUIPMENT

In addition to its line of production machinery, Westpro manufactures a comprehensive range of pilot- & laboratory- scale equipment. Designed with the same focus on quality and ease of operation, these units are perfectly suited for mineral processing laboratories and pilot / demonstration plants.

Units can be designed in either batch or continuous configuration, depending on project requirements. The availability of standard equipment with numerous equipment customization options allows Westpro the flexibility to meet the variety of challenges posed by novel process technologies.

Westpro's laboratory and pilot equipment line includes:

- Agglomerators
- Agitators
- Attrition Scrubbers
- Cone crushers
- Clarifiers
- Filter Press
- Flotation Machines
- Grinding Mills
- Hopper Feeders
- Jaw Crushers
- Rolls Crushers
- Rotary dryers
- Thickeners
- and more

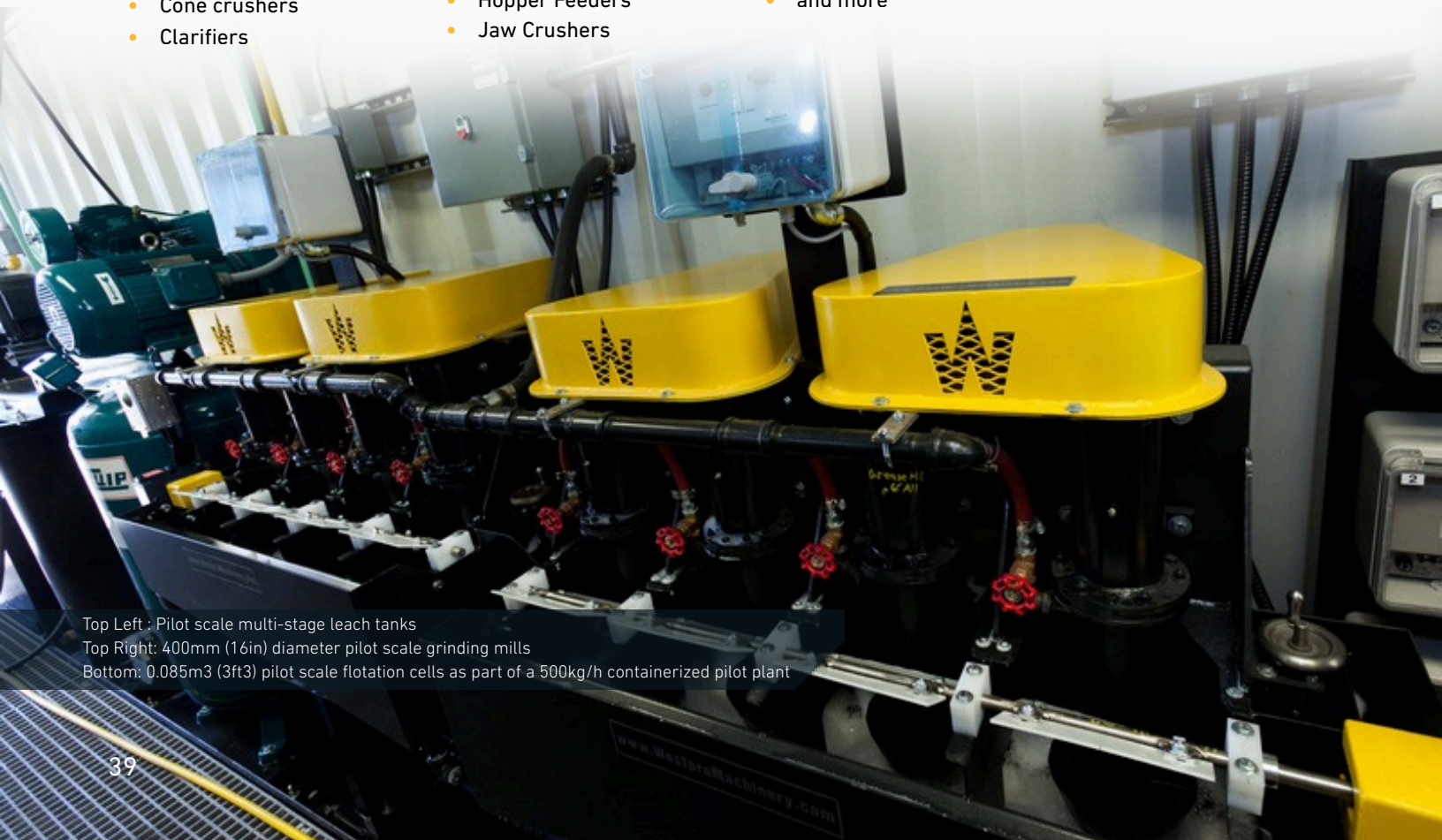

Top Left : Pilot scale multi-stage leach tanks
 Top Right: 400mm (16in) diameter pilot scale grinding mills
 Bottom: 0.085m³ (3ft³) pilot scale flotation cells as part of a 500kg/h containerized pilot plant

**WESTPRO DELIVERS
QUALITY MACHINERY
TO ASSIST OUR
CUSTOMERS IN
ACHIEVING PEAK
PERFORMANCE**





WESTPRO PRODUCTION FACILITY

Westpro's Service and Manufacturing facility is located in Puslinch, Ontario and has 20,000 sq. feet of fabrication and assembly space as well as material handling equipment of up to 50 tons. We have on-site machining capabilities and a skilled labour team to handle complete builds of new equipment and re-furbishing for all our mining, aggregate and wastewater customers.

The Production Facility offers the following services to Westpro's customers:

- CWB certified welding
- CNC plasma cutting
- Machining, fabrication and assembly
- Equipment inspection, optimization & refurbishment
- Established & proven QA procedures
- Trial fit and testing
- Equipment and spare parts shipping
- Best lead times in the industry

Top Left : Modular Jaw Crusher trial-fit at the Westpro Production Facility

Top Right: Lifting of JC4050 jaw crusher frame with Westpro Production Facility cranes

Bottom: Highly trained Westpro shop personnel





SERVICE & SUPPORT

As a customer-focused company, Westpro is committed to keeping its customers running. Westpro has an established customer service and support division at its Ontario and British Columbia locations, capable of servicing installations in all corners of the globe.

Westpro has a dedicated, multi-lingual team of customer service staff trained to support Westpro's mineral processing technology. Westpro's experienced service engineers are available for on-site services. The services provided by Westpro's service division include:

- Original OEM Spare Parts
- Equipment Installation and Site Support
- Equipment Commissioning (Mechanical & Process)
- Troubleshooting
- Equipment Audits
- Process Consulting
- Equipment Reconditioning
- And more

CONTACT WESTPRO TODAY TO FIND OUT HOW WE CAN HELP YOU TO OPTIMIZE THE PERFORMANCE OF YOUR MINERALS PROCESSING TECHNOLOGY

Top Left: Commissioning of Conventional Flotation Machines at a potash plant in Chile
Top Middle: Commissioning a 1.5m (5ft) diameter grinding mill in Manitoba, Canada
Top Right: Commissioning a 2.4m (8ft) diameter agglomerator in Mexico
Bottom: Installation of one of the world's largest Attrition Scrubbers at a potash plant in Saskatchewan, Canada





GRINDING MILL RECONDITIONING

Utilizing over three decades of experience in the manufacture of mineral processing equipment, Westpro is ideally positioned to assist you with your grinding mill reconditioning needs. With a team of highly experienced engineers, technicians and factory-trained professionals, Westpro offers the fastest lead times in the industry for the reconditioning of all mill types and sizes.

Westpro's commitment to service excellence is reflected in our comprehensive reconditioning services, specifically designed to produce a quality product that is backed by a standard Westpro Warranty.

Westpro's reconditioning services include:

- Site visits and inspections
- Inspection report and reconditioning recommendations
- Mill removal and transport to nearby Westpro authorized refurbishing facility
- Mill reconditioning
- Transport to site and installation of reconditioned mill at site
- Commissioning
- 6-month Westpro warranty for reconditioned equipment and after-sales service

Top: Installation of reconditioned 7.3m (24ft) diameter SAG Mill on-site

Bottom Left: Reconditioned ball mill on-site at a mine in Mexico

Bottom Middle: 7.3m (24ft) diameter SAG mill head remanufacturing

Bottom Right: Grinding mill motor reconditioning

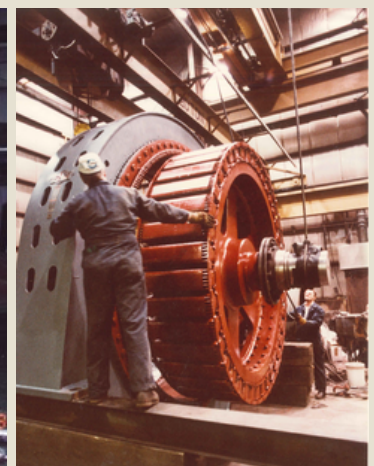

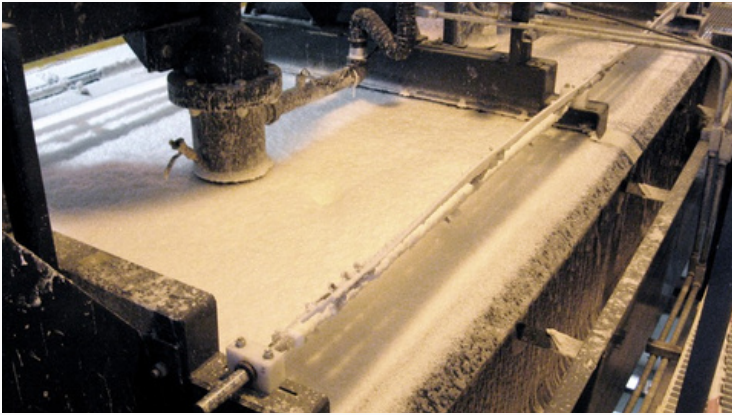

FLOTATION RETROFITS

Westpro is an industry leader in flotation technology with leading expertise in the process and mechanical design of flotation machines. Westpro can boost the performance of your flotation circuit by retrofitting existing cells with Westpro's proprietary mechanisms developed through extensive R&D.

Westpro engineers custom-configure each retrofit solution based on the process data and drawings supplied by the customer. The mechanisms are designed to integrate into existing flotation tanks and deliver reliable, long-life operation.

Westpro offers flotation retrofit solutions for both conventional flotation machines and tank cells:

- Conventional flotation machines
 - Upgrade existing Denver / Metso mechanisms to Westpro flotation mechanisms
 - Improve flotation performance by converting to Westpro's rotor-stator style mechanism design
- Tank cells
 - Upgrade to Westpro's new generation

W19 rotor stator for:

- Improved bubble generation
- Improved slurry suspension
- Improved slurry-air contact

Above Left: Excellent slurry suspension and froth production performance in a Westpro potash flotation cell

Above Right: Installation of Westpro flotation mechanism in a conventional flotation machine in Chile

Bottom: Westpro Conventional Flotation Machine mechanisms prior to shipping





THICKENER RETROFITS

Boost the performance of your conventional thickeners by retrofitting them with Westpro's high capacity thickener mechanisms and feed wells. Westpro's industry-leading thickening technology delivers superior dewatering performance and provides capacity increases of up to 50% and beyond.

Each thickener retrofit application is analyzed by Westpro's experienced team of engineers to develop customized solutions for superior dewatering performance and ease of installation on site. Installed on existing tanks and infrastructure, Westpro's High Capacity Thickener Retrofits provide an efficient and cost-effective solution for plant expansion and optimization projects.

Westpro's High Capacity Thickener Retrofit Kit:

- Efficient hydraulic drive
 - Single unit for rake rotation and rake lift
 - Robust design and high torque capability
- Low drag – high capacity rakes
 - Engineered for high torque applications
- Optimized feed well designs
 - Design using CFD technology
- Local control system with PLC

Above Left: 16.8m (55ft) diameter thickener retrofit, providing increased thickener capacity for over 10 years

Above Middle: View of a retrofitted hydraulic drive of a 14.6m (48ft) diameter thickener in Mexico

Above Right: 18m (60ft) diameter thickener at a silver processing plant in Mexico, retrofitted with Westpro's High Capacity mechanism

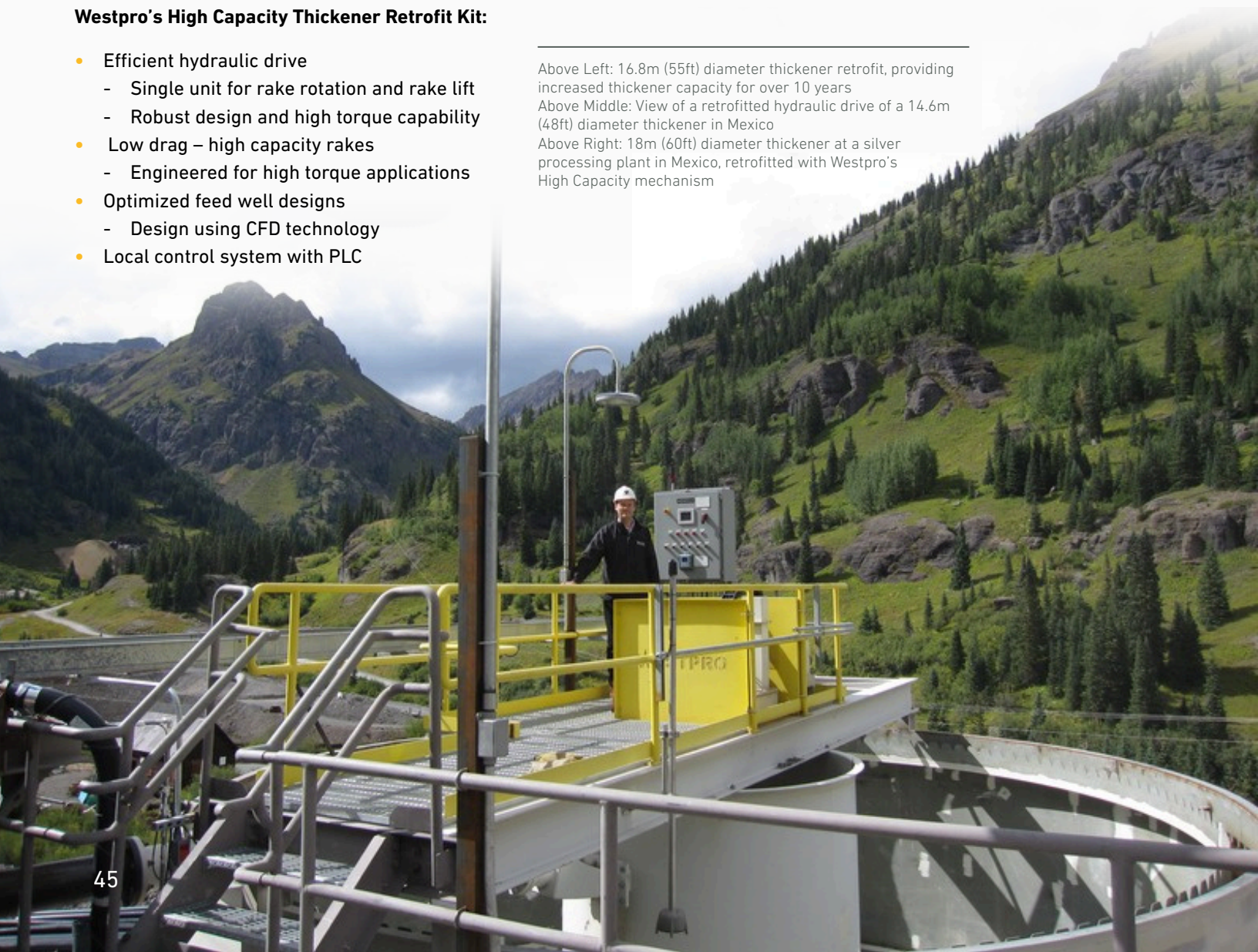

**EQUIPMENT
COMMISSIONING
AND INSPECTION
PERSONNEL AVAILABLE
AT SITES WORLDWIDE**





GLOBAL REACH

Installations in 20+ countries world-wide

TECHNOLOGY DELIVERED



Westpro Machinery Inc. is an innovative Canadian mineral processing technology company with over 40 years of experience in the mineral processing industry. Westpro designs and manufactures a full range of mineral processing equipment, as well as providing services for equipment commissioning, equipment remanufacturing services, spare parts, process design and process consulting. Westpro's commitment to excellence has established it as a global leader in the supply of quality machinery and related services.

Contact Westpro, your process technology partner today. Contáctenos, para nosotros será un placer servirle.

Westpro Machinery Inc.

3317 30th Avenue, Suite 202
Vernon, BC
V1T 2C9 Canada

T: +1.250.549.6710
F: +1.250.549.6735

Westpro Machinery Inc.

1177 West Hastings St., Unit 2088
Vancouver, BC
V6E 2K9 Canada

T: +1.250.549.6710

Westpro Machinery Inc.

33 Kerr Crescent
Puslinch, ON
N0B 2J0 Canada

T: +1.519.766.9462
F: +1.519.766.9692

Westpro Machinery Inc.

2255 Glades Road, Suite 324A
Boca Raton, Florida
USA, 33431

T: +1.877.937.8776

www.westpromachinery.com | sales@westpromachinery.com